

BOROUGH OF MILLERSVILLE

Lancaster County, Pennsylvania

ORDINANCE NO. 2026-06

AN ORDINANCE TO AMEND AND RESTATE CHAPTER 320, STREETS AND SIDEWALKS, OF THE MILLERSVILLE BOROUGH CODE OF ORDINANCES.

BE AND IT IS HEREBY ORDAINED AND ENACTED by Borough Council of the Borough of Millersville, Lancaster County, Pennsylvania, as follows:

Section 1. The Millersville Borough Code of Ordinances, Chapter 320, Streets and Sidewalks, shall be restated in its entirety to provide as follows:

ARTICLE I

**LEGISLATIVE INTENT, DEFINITIONS, AND WORD USAGE
APPLICABLE TO CHAPTER 320**

§320-1.01 STATEMENT OF FINDINGS AND PURPOSE.

- A. Borough Council finds that ordinances are required to establish criteria, rules, and regulations for access to a Borough street or the construction and maintenance of any road, street and/or stormwater management facility within street rights-of-way. Borough Council also finds that regulations are necessary for construction, maintenance and use of sidewalks.
- B. The purpose of this chapter is to establish criteria for access to a Borough street and sidewalk or for construction and maintenance of roads, streets, driveways, curb, sidewalk, utilities and storm water management facilities within street rights-of-way, including a procedure for the acceptance and dedication of streets upon satisfactory completion of their construction.

§320-1.02 WORD USAGE.

- A. In this chapter, the following rules of interpretation shall be used:
 - (1) Words in the singular include the plural, and words in the plural include the singular.
 - (2) Words in the present tense may imply the future tense.
 - (3) The word "building" shall be construed as if followed by the words "or part thereof."
 - (4) The word "street" includes "road," "highway" and "lane".
 - (5) The word "watercourse" includes "drain," "ditch," and "stream."

(6) The words "shall" or "will" are mandatory, and the word "may" is permissive.

(7) The word "lot" includes the word "plot," "parcel," or "tract."

B. References to codes, ordinances, resolutions, plans, maps, governmental bodies, commissions, agencies, or officials are to codes, ordinances, resolutions, plans, maps, governmental bodies, commissions, agencies, or officials of this Borough as in effect or office from time to time, including amendments thereto or revisions or successors thereof, unless the text indicates that another reference is intended. References to officially adopted regulations, standards, or publications of PennDOT or other governmental agencies shall include the regulation, publication, or standard in effect on the date when a plan is first filed. It is the intent of Borough Council in enacting this section to incorporate such changes to statutes, regulations, and publications to the extent authorized by 1 Pa. C.S. §1937.

C. The time within which any act required by this chapter is to be performed shall be computed by excluding the first day and including the last day. However, if the last day is a Saturday or Sunday or a holiday declared by the United States Congress or the Pennsylvania General Assembly, it shall also be excluded. The word "day" shall mean a calendar day, unless otherwise indicated.

D. If a term is not defined by this article, but is defined in Chapter 380, Zoning, Chapter 325, Subdivision and Land Development, or Chapter 315, Stormwater Management, the definition in that other chapter shall apply to this chapter. Words defined in the MPC and not defined in this chapter shall have the meanings set forth in the MPC. If a term is not defined in any of those chapters or the MPC, then the term shall have its plain and ordinary meaning, within the context of the provision. A standard reference dictionary may be consulted in such case.

§320-1.03 DEFINITIONS.

Unless otherwise expressly stated, the following terms shall, for the purpose of this chapter, have the meanings indicated in this section:

AASHTO -- American Association of State Highway Transportation Officials.

Access - A way or means of approach for vehicle and/or pedestrian traffic from a street, right-of-way, public area or community facility to a lot and/or vice versa.

ADA -- The United States Americans with Disabilities Act and all regulations adopted pursuant thereto.

Alley – See Street, Alley.

Applicant/ Permittee – Any person who has made an application under this chapter or who has been issued a permit under this chapter.

Approved – Approved by the recognized authoritative agency or official as specified in the respective regulations.

Borough – The Borough of Millersville, County of Lancaster, Commonwealth of Pennsylvania.

Borough Council - The governing body of the Borough.

Borough Engineer – A professional engineer licensed as such in the Commonwealth of Pennsylvania, duly appointed as the Engineer for the Borough.

Borough Official – The Borough Manager, Streets Superintendent, Zoning Officer, Code Official/Officer, Borough Engineer or other Borough designee.

Cable Act – The Cable Communications Policy Act of 1984, as amended by the Cable Television Consumer Protection and Competition Act of 1992 and the Telecommunications Act of 1996, and as hereafter amended (47 U.S.C. §§ 521 et seq., as hereafter amended).

Cable Franchise – Authorization granted by the Borough in accordance with the Cable Act, authorizing a person to own, construct, operate and maintain a cable system to provide cable service within the Borough.

Cable Operator – A person providing or offering to provide cable service over a cable system within the Borough as that term is defined in the Cable Act.

Cable Service - The one-way transmission to subscribers of video programming or other programming service and subscriber interaction, if any, which is required for the selection or use of such video programming or other programming service.

Cartway – The surface of a street or alley available for vehicular traffic.

Clear Sight Triangle - An area of unobstructed vision at street intersections defined by lines of sight between points at a given distance from the intersection of the street centerlines.

Cul-de-Sac – A special turning area for a vehicle at the end of a street.

Curb - Any monolithic or modular material, such as concrete, limestone or brick, which runs parallel to streets and sidewalks and projects above the street and is installed and intended to protect the street from raveling, to channel rainwater or to support an adjacent sidewalk. Whenever a curb is located closer than six inches to an adjacent sidewalk, the top shall be considered part of the sidewalk.

Curbline – A line formed by the face of the existing curb or as established by the Borough.

Developer – Any landowner, agent of such landowner or tenant with the permission of such landowner who makes or causes to be made a subdivision of land or a land development.

Driveway – A private drive providing pedestrian and vehicular access between a public or private street and a parking area.

- A. High Volume – A driveway used or expected to be used by 1500 or more vehicles a day.
- B. Joint use – A driveway shared by and constructed to provide access to two or more properties or uses.
- C. Low Volume – A driveway used or expected to be used by more than 25 but less than 750 vehicles per day.
- D. Medium Volume – A driveway used or expected to be used by 750 or more but less than 1500 vehicles per day.
- E. Minimum Use – A residential or other driveway which is used or expected to be used by not more than 25 vehicles per day.

Driveway Width – The narrowest width of a driveway measured perpendicular to the centerline of the driveway.

Easement – A right-of-way granted for limited use of the land for public or quasi-public purpose.

Emergency – Any unforeseen circumstance which calls for immediate action to protect or safeguard life or property.

Engineer – A professional engineer registered in the Commonwealth of Pennsylvania.

Excavate/Excavation – Any activity within the right-of-way of any street which involves cutting, drilling, boring, tunneling, breaking or disturbance of the surface thereof or any and all facilities and/or appurtenances located within the street (by way of example only: curbing, gutter, sidewalk, storm sewers, utilities and traffic control devices).

Facilities – Conduit, pipes, cables, wires, lines, towers, optic fiber, antennae, poles, associated equipment and appurtenances, and any other infrastructure or materials located in the right-of-way and designed, constructed, and/or used, by right-of-way occupants for transmitting, transporting, or distributing communications, telecommunications, electricity, natural gas or manufactured gas, oil, gasoline, steam, or any other form of energy, signal or substance, or for any other lawful purpose.

Final Plan -- A final subdivision or land development plan meeting requirements of Chapter 325, Subdivision and Land Development.

Grade, Finished – The completed surfaces of lawns, walks and streets brought to grades as shown on official plans or designs relating thereto.

Improved Area – The area within the street right-of-way which has been constructed for local street purposes, including roadbed, pavement, shoulders, slope, sidewalks, stormwater management facilities and any other appurtenances.

Land Development – Any activities meeting the definition of land development in Chapter 325, Subdivision and Land Development.

Landowner – The legal or beneficial owner or owners of land, including the holder of an option or contract to purchase (whether or not such option or contract is subject to any condition), a lessee if he/she is authorized under the lease to exercise the rights of the landowner, or other person having a proprietary interest in land.

Local Street – See Street.

Lot – A designated parcel, tract, or area of land established by a plat or otherwise as permitted by law and to be used, developed or built upon as a unit.

MPC -- The Pennsylvania Municipalities Planning Code, 53 P.S. §10101 et seq.

MUTCD -- The Federal Highway Administration Manual on Uniform Traffic Control Devices.

Open/Opening – Any cutting or excavating of the surface or soil of any street, sidewalk area or public Borough property.

Pavement Edge – The edge of the main traveled portion of any roadway, exclusive of shoulder.

PennDOT -- The Pennsylvania Department of Transportation or any agency successor thereto.

Permit – A license issued by the recognized official or authoritative agency, as specified in the respective regulations, which permits the applicant to proceed with the work certified by said official or authoritative agency in the permit application.

Permit Official - The employee or agent of the Borough involved with the administration, review or enforcement of any provisions of this chapter by appointment, contract or memorandum of understanding and any person, including but not limited to the Borough Engineer, providing assistance to the Permit Official.

Person - Any natural person, partnership, firm, association, organization, company, corporation, utility, municipal authority or other legally recognized entity.

Public Utility – Any entity that is currently certificated as a public utility by the Public Utility Commission.

Public Utility Commission (PUC) – The Public Utility Commission of the Commonwealth of Pennsylvania or any agency successor thereto.

Publication 408 – The current PennDOT specifications.

Recorder of Deeds -- The Recorder of Deeds in and for Lancaster County, Pennsylvania.

Rights-of-Way – The surface and the area across, in, over, along, under and upon the public streets, roads, lanes, avenues, alleys, sidewalks, bridges, highways and other rights-of-way, as the same now or may thereafter exist, which are under the jurisdiction or control of the Borough.

Right-of-Way Occupant – An applicant for, or recipient of, a Right-of-Way Agreement, Right-of-Way Construction Permit or Cable Franchise that is issued by the Borough pursuant to this chapter, and persons holding existing franchises, special ordinances, or other authorizations for use of the rights-of-way, or otherwise maintaining facilities in the rights-of-way including the Borough, its departments, agencies, and authorities.

Right-of-Way Construction Permit or Permit – A permit issued by the Borough authorizing use of the public rights-of-way, issued pursuant to this chapter.

Right-of-Way Use Agreement – An agreement authorizing use of the rights-of-way by a person seeking to construct, maintain, and operate Facilities within the rights-of-way of the Borough.

Road – See Street.

Roadway – That portion of a surface improved, designed or ordinarily used for vehicular travel, exclusive of the sidewalk or shoulder.

Roadway Construction Standards – PennDOT Publication No. 72 containing PennDOT's design standards for roadway construction.

Sewer Superintendent -- The person appointed superintendent or head of the Borough Wastewater Treatment Department.

Sidewalk – A paved walkway, continuous for a reasonable distance and an integral part of the roadway, with or without a grass strip between the curb or cartway edge and the sidewalk, constructed solely for use

by pedestrians OR any paved or unpaved surface on or along the right-of-way of public streets used or obviously intended for use by pedestrians traveling along said street. It shall include paved surfaces such as concrete, asphalt, flagstone, brick, slate or other monolithic or modular building material.

Sight Distance – The length of street visible to the driver of a vehicle at any given point in the street when viewing is unobstructed by traffic.

Stopping Sight Distance – The distance required by a driver traveling at a given speed to stop the vehicle after an object on the roadway becomes visible to the driver.

Street – Includes street, avenue, boulevard, road, highway, freeway, parkway, lane, alley, viaduct or any other way used or intended to be used by vehicular traffic (excluding driveways), whether public or private. Streets shall conform to one of the following categories:

- A. **Alley** – A vehicle right-of-way having a maximum right-of-way width of 20 feet and that usually provides secondary access to the side or rear of one or more lots and which is not intended for through traffic.
- B. **Arterial** – A street whose primary function is to serve comparatively high volumes of through traffic at speeds higher than desirable on collector and local streets.
- C. **Collector** – A street which, in addition to providing access to abutting properties, collects traffic from the local street system.
- D. **Local** – A street used primarily to provide access to abutting properties.
- E. **Cul-de-sac Street** - A street intersecting another street at one end and terminating at the other in a vehicular turnaround.
- F. **P Street** - Any local street which does not intersect with a through street at two separate and distinct locations. A P-street includes a street which intersects with a through street, extends and then loops back upon itself in roughly the shape of a P or a street which intersects with one or more other streets, all of which are either cul-de-sac streets or streets which merge through various intersections to all be served by a single connection with a through street.

A graphic representation of through streets, cul-de-sac streets and P-streets is as follows:

1 = Through street.

2 = Cul-de-sac street.

3 = P-street.

B = Beginning point to measure the length of a cul-de-sac or P-street.

E = Ending point to measure the length of a cul-de-sac or P-street.

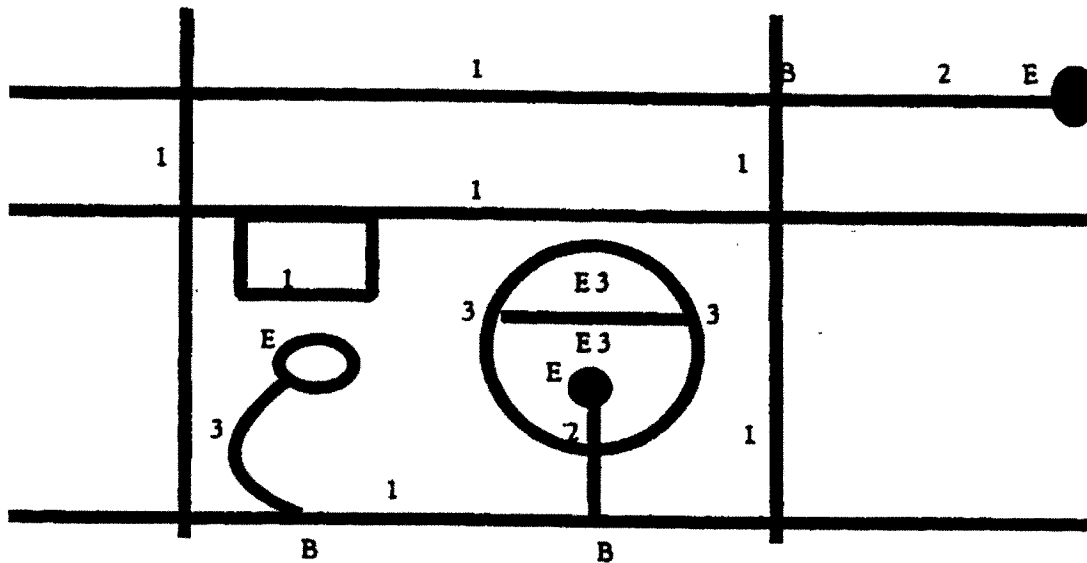

Street Centerline – The center of the surveyed road right-of-way; or where not surveyed, the center of the traveled cartway.

Street Grade – The officially-established grade of the street upon which a lot fronts; or in its absence, the established grade of other streets upon which the lot abuts, at the midpoint of the frontage of the lot thereon. If there is no officially established grade, the existing grade of the street at such midpoint shall be taken as the street grade.

Streets Superintendent -- The appointed superintendent or head of the Borough Streets Department.

Traffic Control Device – Any sign, signal, marking, or device placed or erected for the purpose of regulating, warning, or guiding vehicular traffic or pedestrians, or both.

Vehicle – Every device in or by which any person or property is or may be transported.

§320-1.04 CONTINUANCE OF PRIOR REGULATIONS.

Except as otherwise required by law, this chapter is intended as a continuation of, and not a repeal of, existing regulations governing the subject matter. To the extent that this chapter restates regulations contained in ordinances previously enacted by Borough Council, this chapter shall be considered a restatement and not a repeal of such regulations. It is the specific intent of Borough Council that all provisions of this chapter shall be considered in full force and effect as of the date such regulations were initially enacted. It is expressly provided that the provisions of this chapter shall not affect any act done, contract executed or liability incurred prior to its effective date, or affect any suit or prosecution pending or to be instituted to enforce any rights, rule, regulations or ordinance, or part thereof, or to punish any violation which occurred under any prior subdivision and land development regulation or ordinance. In the event any violation has occurred under any prior subdivision and land development regulation or ordinance of the Borough, prosecution may be initiated against the alleged offender pursuant to the provisions of said prior subdivision and land development regulation or ordinance, and the provisions and penalties provided in said prior subdivision and land development regulation or ordinance shall remain effective as to said violation.

ARTICLE II

STREET OPENINGS AND EXCAVATIONS

§320-2.01 GENERAL RULE.

It shall be unlawful for any person to open or to make any excavation in any street in the Borough unless such person has obtained a permit under this article.

The Borough reserves the right, in its discretion, to waive, or to waive subject to conditions, any or all of the requirements of this article relating to furnishing of confession of judgment, public liability insurance and performance bond in cases of street opening permit applications for work to be performed by public utility corporations by their own employees (but not by their contractors), upon submission by such corporations of condensed financial statements and/or certificates of self-insurance which they shall consider to establish that such waivers may be granted without prejudice to the interests of the Borough and its taxpayers, and if such corporations shall have theretofore faithfully complied with all requirements of Borough ordinances.

The property owner or utility company for whose benefit the work is to be done shall be jointly and severally responsible (regardless of whether or not all owners have signed the application for the permit required hereunder) for compliance with the permit requirements listed in this article.

§320-2.02 APPLICATION PROCEDURES.

- A. Who May Execute Applications. Permits shall only be issued to persons furnishing public utility services or owning real property adjoining the location where the opening or excavation is to be made.
- B. Where to Submit Application. Permit applications shall be submitted to the Borough on any legal business day during normal business hours.
- C. When to Submit Applications. Permit applications for streets excavations shall be submitted prior to the commencement of any construction.
- D. Review Procedures. A permit shall be issued to the applicant or the Borough shall provide written notice of disapproval together with the reasons therefor to the applicant.

§320-2.03 APPLICATION FORMS AND REQUIRED INFORMATION.

- A. Permit applications for street excavations:
 - (1) Shall be submitted in person, by mail or as designated by the Borough;
 - (2) Shall be submitted on a properly completed Borough permit application form;
 - (3) Shall be signed by the applicant;
 - (4) Shall include two sets of plans, of a quality sufficient for photocopying or scanning, detailing the location and pertinent dimensions of both the proposed installation and related roadway features;

- (5) Shall be accompanied by a check or money order, payable to the Borough, in the amount of the required permit fee;
 - (6) Shall be submitted to the Borough at least 10 working days prior to the anticipated start of work; and
 - (7) Shall contain proof of ownership.
- B. Permit applications involving public sewer or other utility:
- (1) Where the street opening permit is required for public sewer purposes, the application shall be countersigned by the Sewer Superintendent or his/her designee before the Borough shall issue the permit.
 - (2) Where the street opening permit is for a utility other than public sewer, the applicant shall present evidence that the utility has consented to the work.
- C. Permits with respect to state highways shall be subject to any additional requirements of PennDOT.
- D. Except in emergency situations, a permit shall be issued to the applicant by the Borough after all requirements for the issuance thereof have been completed. If the application is disapproved, written notice of disapproval together with the reasons therefor shall be given to the Applicant.

§320-2.04 PLAN REQUIREMENTS.

The permit application shall include a plan which illustrates, at a minimum, the following, including dimensions where applicable:

- A. Exact location of the proposed opening or excavation and the approximate size or depth thereof.
- B. Typical details showing how the opening will be repaired including material thickness and type.
- C. The plan shall be of the quality required for the excavation, construction, and repair of the street.

§320-2.05 STREET OPENING PERMIT EXEMPTIONS.

- A. The obtaining of street opening permits by Borough departments shall be waived when work is to be performed completely by Borough personnel.
- B. The obtaining of street opening permits by contractors shall be waived when work is to be performed as part of a Borough public works project.

§320-2.06 EMERGENCY EXCAVATIONS.

- A. In the case of any leak, explosion, or other accident in any subsurface pipe, line, construction, or apparatus, it shall be lawful for the person owning or responsible for such pipe, line, construction or apparatus, to commence excavation to remedy such condition before securing a permit, provided that application for a permit shall be made immediately and not later than five regular business days thereafter, and that all other provisions of this article are fully complied with. Said permit shall be retroactive to the date when the work began.

- B. A person performing street openings for an emergency must certify the emergency nature of the circumstance in writing to the Borough within five regular business days following such emergency.
- C. A person performing street openings for an emergency must notify the Borough Police Department (written or verbal) of the location of the emergency street opening prior to commencing the emergency operation, either en route or at the scene.
- D. If any such emergency condition shall not be immediately attended to by the owner or person responsible for such pipe, line, construction or apparatus, the Borough, after such notice as it deems necessary under the circumstances of the particular case, shall proceed to do the work necessary and required by such emergency and charge the same on the basis of cost plus 20% to such owner or person.
- E. Failure to apply for the street opening permit within the specified time period will result in a penalty established by Borough Council and may be changed from time to time by resolution of the Borough Council.

§320-2.07 EXCAVATION REQUIREMENTS AND SPECIFICATIONS.

The property owner or utility company for whose benefit the work described in this article is to be done shall be jointly and severally responsible (regardless of whether or not all owners have signed the application for the permit required hereunder) for compliance with this article.

- A. All work in Borough streets governed by this article and for which the permit has been issued in accordance herewith shall be done in accordance with and pursuant to the Appendix B.
- B. The Borough shall have the full authority to establish standards for paving and backfilling materials and associated procedures. Details specifying paving and backfilling procedures and materials shall be obtained from the Borough prior to any street opening work. The type of backfill material (either flowable backfill, 2A Crushed Stone or other materials) shall be as directed by the Streets Superintendent or designee.
- C. Any person who shall open or excavate any street in the Borough shall thoroughly and completely refill the opening or excavation as to prevent any settling thereafter, and shall restore the surface and appurtenances (appurtenances include, but are not limited to, curbs, sidewalks, storm sewers, utilities and traffic control devices) to no worse condition than they were before the opening or excavation. As restored, the surface shall conform to the proper grade and be of the same surface covering as the part of the thoroughfare immediately adjoining the opening.
- D. All work in connection with the permit (including all items shown on the plans and specifications submitted to obtain the permit and any and all incidental work required to complete the work to the satisfaction of the Streets Superintendent) shall be done by or for the person to whom the permit has been issued at the permittee's sole expense.
- E. Any person performing work pursuant to a permit issued hereunder shall at all times comply with all applicable federal, state and local laws, rules, regulations, provisions, and policies governing health and safety, including without limitation the Federal Construction Safety Act (Public Law 91-54), Federal Register, Chapter XVII, Part 1926 of Title 29 Code of Federal Regulations, Occupational Safety and Health Regulations for Construction.

- F. Access to all driveways shall be maintained except for short durations of time for construction of utilities, curb, sidewalk or paving. The contractor shall notify the property owners 24 hours in advance prior to closing the driveway. The driveway must be open and passable at the close of each working day unless approved by the Borough.
- G. The contractor shall take all necessary and reasonable precautions to ensure that the street remains in a safe and passable condition for the traveling public at all times. Such precautions may include but are not limited to the use of signs, barriers, lanterns, and all other warning devices sufficient to alert the traveling public of possible dangers relative to the excavation.
- H. No opening or excavation in any street shall extend from the curblines into the cartway a distance greater than one foot beyond the center line of the street before being refilled. The surface of the cartway shall be restored to a condition safe and convenient for travel.
- I. All openings and excavations shall be backfilled promptly. At the close of each working day, the contractor must have all lateral trenches backfilled, all driveways open and all open trenches either backfilled or covered with steel plates.
- J. The use of steel plates to cover open excavations shall be prohibited at all times between October 15 and April 15 unless the Borough grants prior approval in writing.
- K. No more than 500 feet longitudinally shall be opened in any street at any one time.
- L. The applicant shall be responsible to replace all pavement markings and signs that are removed or damaged. All material shall be in conformance with Borough Technical Specifications, the MUTCD and PennDOT requirements.
- M. The permission herein granted does not confer on the permit holder or its contractors the right to cut, remove or destroy trees or shrubbery within the legal right-of-way except under specifications, regulations, and conditions as the Streets Superintendent or Borough Official may prescribe.
- N. The work of excavation shall be so conducted as not to interfere with any existing underground utility line or lateral or aboveground utility line without first contacting the owner of such utility and obtaining written permission from them for the work.
- O. Construction, extension or replacement of existing water, sewer, steam or gas main or electric, telephone, cable or other utility shall be at a minimum depth of 30 inches from the surface of the street unless approved by the Borough Official.
- P. All excavation permits are granted under and subject to the express condition that the permittee shall indemnify, save and keep harmless the Borough from any loss in damages or otherwise whatsoever which may or shall be occasioned at any time by the said excavation or by any leak, explosion or other injury from any pipes, apparatus, conduit or any other matter placed in the said excavation. The permittee shall be responsible to comply with the Pennsylvania Underground Utility Protection Act, unless specified otherwise in an agreement with the Borough.
- Q. If at any time in the future the roadway is widened, reconstructed or the alignment or grades are changed, the permit holder further agrees to change or relocate all or any part of the structures covered by this permit which interfere with the improvements of the roadway at the permit holder's own cost and expense.

§320-2.08 REQUIREMENTS FOR PAVEMENT RESTORATION.

- A. If a street opening exceeds 10 linear feet in length, the entire area shall be milled and overlaid for a width of 1/2 the street/alley width, unless the repair crosses the center line of the street/alley, then the mill and overlay shall be for the full width of the street/alley.
- B. If two or more street openings are made less than 100 feet apart, the entire area between the two openings and including the two openings shall be milled and overlaid for a width of 1/2 the street/alley width, unless the repair crosses the center line of the street/alley, then the mill and overlay shall be for the full width of the street/alley.
- C. If four or more openings are made within a 500-foot span, the entire area between and including the openings shall be milled and overlaid for a width of 1/2 the street/alley width, unless the repair crosses the center line of the street/alley, then the mill and overlay shall be for the full width of the street/alley.
- D. When the opening is to be closer than three feet from the edge of the existing pavement, the opening shall be extended to the edge of pavement.
- E. When the opening is to be closer than five feet from the edge of an existing patch or patches in the pavement, the restoration shall be extended to include said patch.
- F. When the opening is located in a street 16 feet wide or less, then the applicant shall overlay the entire street width for the entire length of the opening.
- G. Any applicant test boring or drilling into any Borough street for location of leaks or venting of leaks shall be required to backfill holes as directed by the Streets Superintendent or his/her designee.
- H. Trenches shall remain unpaved for no longer than five business days after backfilling and shall not remain unpaved during any weekend or any holiday officially observed by the Borough.
- I. Temporary paving shall be placed and maintained for a maximum of 180 days. Temporary paving shall be thoroughly bound and compacted, installed flush with the surface of the adjoining paving. Such temporary paving material and thicknesses shall be in accordance with Appendix B. Alternate temporary paving consisting of cold patch may be used on a case-by-case basis if approved in writing by the Borough Official.
- J. Permanent paving shall be thoroughly bound and compacted, installed flush with the surface of the adjoining paving. Such permanent paving material and thicknesses shall be in accordance with Appendix B. All temporary paving material shall be removed from trenches prior to placement of the permanent paving base course.

§320-2.09 MORATORIUM ON STREET OPENINGS.

- A. The Borough shall give timely notice to all persons owning property on or abutting to any street within the Borough about to be resurfaced or reconstructed, and to all public utility companies operating in the Borough. All such persons and utility companies shall make all water, gas or sewer connections as well as any repairs thereto which would necessitate excavation of the said street within 30 days from the giving of such notice, unless such time is extended in writing for cause shown by the Borough Official

- B. Newly paved streets shall not be opened for a period of five years after the completion thereof except in the case of emergency. If excavation or street opening is sought within five years after the completion of the paving thereof for any other reason than an emergency, the applicant shall make written application to the Borough, and a permit for such opening shall only be issued after express approval of Borough. If a street opening occurs within the five-year period, the Streets Superintendent shall ensure that the street opening is restored satisfactorily. The restoration must include pavement restoration (milling and repaving) for the full-width of the roadway to a distance of approximately 100 feet around the area of the opening.

§320-2.10 PERMIT FEES, DEGRADATION FEES AND BONDING.

- A. Before any permit shall be issued to open or excavate any street within the Borough limits, the applicant shall pay a permit fee to the Borough. This fee will cover the cost of inspection and other services in connection therewith. This permit fee shall be established by resolution of Borough Council.
- B. The applicant shall pay a degradation fee to the Borough upon receipt of a permit to open or excavate a street to defray a percentage of the costs for resurfacing and reconstruction of Borough streets associated with street openings and excavations. The degradation fee shall be in accordance with the degradation fee schedule established by resolution of the Borough Council.
 - (1) If such work or repairs are completed before the street is paved or improved pursuant to this article, the Borough may waive the street degradation fee for the applicant.
 - (2) Where the applicant is required to overlay the street or lane pursuant to this article, the Borough may waive the street degradation fee for the applicant.
- C. Public utility companies desiring to open or excavate a street shall provide the Borough with a bond of indemnity by a reputable surety company licensed to do business in the Commonwealth of Pennsylvania in the amount established by resolution of Borough Council for each calendar year, which amount shall be the same for each year thereafter unless changed by resolution of Borough Council. A bond of indemnity shall be furnished separately for each calendar year by a public utility company and shall be in effect for 36 months.
- D. All other persons or entities, including contractors performing work for the Borough, desiring to open or excavate a street shall furnish to the Borough a properly executed surety bond. All such bonds furnished shall be executed by a reputable surety company licensed to do business in the Commonwealth. All such bonds shall cover street opening or excavating work performed during one calendar year and shall be in effect for a 36 month period. The amount of the surety bond shall be established by resolution of Borough Council. The amount shall be the same for each year thereafter unless changed by resolution of Borough Council.

§320-2.11 RESTORATION AND MAINTENANCE FINANCIAL SECURITY.

No person shall excavate any street without first giving to the Borough a performance guarantee in an amount as determined by the Borough and acceptable to the Borough Council or its designee. Without limitation as to other types of financial security which the Borough may approve, which approval shall not be unreasonably withheld, irrevocable letters of credit issued by a federal or state-chartered bank or lending institution or restrictive escrow accounts held by such banks or lending institutions shall be deemed acceptable financial security for the purposes of this article.

§320-2.12 AS-BUILT PLAN OF UNDERGROUND FACILITIES AND STRUCTURES.

Within 60 days after completion of installation of any pipe, conduit or other underground structure under any Borough street or sidewalk by any party other than a Borough employee or contractor (acting under Borough authority), the applicant for the permit authorizing such work shall file or procure the filing showing the exact size, location and depth of the underground facilities or structures, with tie-in measurements to enduring surface monuments, accompanied by a certificate by the applicant or his/her contractor that the installation, as actually made, was in conformity with the location and any other specifications prescribed by the permit.

§320-2.13 VIOLATIONS AND PENALTIES.

Any person who violates or permits the violation of any provision of this article shall be liable, upon summary conviction therefor, to fines and penalties of not less than \$100 nor more than \$1,000 plus all costs of prosecution, including the Borough's reasonable attorneys' fees, which costs, fines, and penalties may be collected as provided by law. Each day that a violation continues and each section of this article which is violated constitutes a separate violation.

ARTICLE III
STREET AND DRIVEWAY CONSTRUCTION

ARTICLE III.A
GENERAL PROVISIONS

§320-3.01 SHORT TITLE.

This article shall be known as the “Millersville Borough Street and Driveway Standards Ordinance.”

§320-3.02 STATEMENT OF FINDINGS.

Borough Council finds that an ordinance is required to establish criteria, rules, and regulations for access to a Borough street or the construction of any road, street and/or stormwater management facility to be dedicated to the Borough, upon satisfactory completion; and prescribing penalties for the violation of this article.

§320-3.03 PURPOSE.

The purpose of this article is to establish criteria for access to a Borough street or for construction of roads, streets, driveways, utilities and storm water management facilities to be dedicated to the Borough, including a procedure for the acceptance and dedication of the same upon satisfactory completion of their construction.

§320-3.04 OTHER REQUIREMENTS.

Issuance of a permit under these regulations does not relieve the permittee from any additional responsibility to secure other Federal, State or Local approvals or permits as may be required by law.

§320-3.05 SAFETY REQUIREMENTS.

Nothing contained in this article is intended to relax existing safety requirements.

§320-3.06 COMPATIBILITY WITH OTHER ORDINANCE REQUIREMENTS.

All plans for streets, driveways, utilities or stormwater management facilities shall comply with the requirements and reflect the information required by those applicable provisions of Chapter 325, Subdivision and Land Development, Chapter 315, Stormwater Management, and with the requirements of this chapter and Federal or State regulations and approvals, all as amended from time to time. Where inconsistencies exist with respect to other ordinances, the terms of this article shall be reconciled if at all possible. If the terms of such other ordinances or regulations are not reconcilable, the ordinance or regulation which provides the stricter standards shall prevail.

§320-3.07 VIOLATIONS AND PENALTIES.

Any person who violates or permits the violation of any provision of this article shall be liable, upon summary conviction therefor, to fines and penalties of not less than \$100 nor more than \$1,000 plus all costs of prosecution, including the Borough’s reasonable attorneys’ fees, which costs, fines, and penalties

may be collected as provided by law. Each day that a violation continues and each section of this article which is violated constitutes a separate violation.

ARTICLE III.B

DESIGN STANDARDS FOR STREETS AND DRIVEWAYS

§320-3.21 GENERAL STANDARDS.

All streets, driveways, curbs and sidewalks shall be designed and constructed in accordance with all requirements of this chapter and the following:

- A. PennDOT Publication 408 or its successor publication.
- B. PennDOT Publication 72 or its successor publication.
- C. PennDOT specifications for ADA-accessible curb ramps, sidewalk and driveway aprons (Pub 72 Standards for Roadway Construction Standard RC-67M).
- D. The ADA.
- E. Chapter 325, Subdivision and Land Development.
- F. Technical Specifications and Standard Details in Appendix B.

§320-3.22 GENERAL REQUIREMENTS FOR STREET DESIGN.

The following criteria shall be considered in the design of streets in all subdivisions and/or land developments.

- A. Borough Council may require that new street connections be provided that comply with the Comprehensive Plan and/or the Official Map, or that are necessary for efficient traffic movement.
- B. Proposed streets shall conform to any county and state street and highway plans as have been prepared, adopted and/or filed as prescribed by law.
- C. Streets shall be logically related to the topography so as to produce reasonable grades, satisfactory stormwater management and suitable building sites.
- D. Residential streets shall be so laid out as to discourage through traffic; however, the arrangement of streets shall provide for the continuation of existing or platted streets and proper access to adjoining undeveloped tracts suitable for future subdivision.
- E. New streets shall be extended to the boundary lines of the development with temporary easements for turnarounds when the subdivision or land development adjoins unsubdivided acreage.
- F. Streets that are extensions of or in alignment with existing streets shall bear the names of the existing streets. Street names shall not be repeated, and all street names shall be subject to the

approval of the Borough, Lancaster County-Wide Communication, and the United States Postal Service.

- G. If lots resulting from original subdivision are large enough to permit re-subdivision or if a portion of the tract is not subdivided, adequate street rights-of-way to permit further subdivision shall be provided as necessary.
- H Half streets at the perimeter of a new subdivision are prohibited.
- I Local streets shall be arranged to discourage excessive speeds when their function is to remain local.
- J Streets shall be laid out to provide convenient and safe access to the development. Where appropriate, Borough Council may require additional cartway improvements and/or right-of-way width along existing street frontages to accommodate the anticipated traffic increase and to facilitate vehicular turning movements to and from individual lots.
- K Plowing easements shall be provided for snow piles at “T” intersections and permanent or temporary cul-de-sacs.
- L All storm water management facilities shall be designed in accordance with Chapter 325, Stormwater Management.

§320-3.23 PRIVATE STREETS.

- A. Private streets may be used if Borough Council determines that no public benefit will be served by dedication. Applications that propose a private street shall be accompanied by a recorded declaration or an agreement which shall be recorded with the Recorder of Deeds as part of the Final Plan. This agreement shall establish the conditions under which the street will be constructed and maintained in accordance with the design approved on the Final Plan, and shall stipulate:
 - (1) Ownership interest in the private street.
 - (2) No limitations on users unless identified in the private agreement.
 - (3) A statement indicating that civil court, not Borough Council, is responsible for mitigating differences relating to the agreement.
 - (4) The method of assessing maintenance and repair cost.
 - (5) Private streets shall not be offered for dedication as a public street unless they are restored to Borough design standards for streets. The offer for dedication of the street shall be made only for the street as a whole.
- B. Private streets are to be discouraged within subdivisions, unless adequate off-street parking is shown to exist, and proper maintenance of all improvements is guaranteed by the developer.
- C. Streets providing circulation between adjacent land developments (existing and proposed) shall be public streets and shall be connected directly to another public street.

- D. There shall be a note on each preliminary and final plan indicating those streets that are not intended for dedication. Private streets shall not be offered for dedication.
- E. There shall be a note on each preliminary and final plan indicating which private streets will have off-street parking.
- F. Private streets shall adhere to all design standards of a public street except for those standards for which private streets are specifically excluded.

§320-3.24 STREET DESIGN STANDARDS.

A. Right-Of-Way and Cartway Widths.

- (1) The right-of-way width and cartway width for local, collector, and arterial streets shall be as shown in Appendix B.
- (2) Where a subdivision or land development abuts or contains an existing street of inadequate right-of-way width, additional right-of-way and cartway width shall be provided to conform to the standards in this chapter. The applicant shall install curbing, sidewalk and pavement widening along the entire length of the proposed subdivision or land development in accordance with this chapter and Chapter 325, Subdivision and Land Development.
- (3) The right-of-way shall be graded to its full width.

B. Vertical Street Alignments.

- (1) Vertical curves shall be used in changes in grade exceeding one percent (1%).
- (2) The minimum lengths (in feet) of vertical curves shall be 25 times the algebraic difference in grade.
- (3) Alignment:
 - (a) Vertical street and driveway alignments shall be measured along the centerline.
 - (b) Minimum Rate of Vertical Curvature K shall be as specified below:

Table 1 Vertical Curve K Values

Initial Speed (mph)	Curvature, K ¹ (ft/%) Crest	Curvature, K ¹ (ft/%) Sag
25	12	26
30	19	37
35	29	49
40	44	64

45	61	79
50	84	96
¹ Rate of vertical curvature, $K = \text{length of curve (L) per percent divided by algebraic difference (A) in the intersection grades (K=L/A)}$		

(4) Grade:

- (a) The minimum grade shall be one (1%) percent.
- (b) The maximum grade shall be eight (8%) percent.
- (c) Where the approaching grade is seven (7%) percent or greater, a leveling area shall be provided within seventy-five (75) feet of a four-way street intersection on the street of lesser classification, or driveway, or the terminating street at a three-way intersection.
- (d) Such leveling area(s) shall have a maximum grade of four percent (4%) for a minimum length of forty (40) feet measured from the intersection of the centerlines.

C. Horizontal Street Alignments.

- (1) Horizontal curves shall be used at all angle changes in excess of one (1) degree.
- (2) The design of horizontal curves shall be based on an appropriate relationship between design speed and curvature and on their joint relationships with superelevation.
- (3) Single, long radius curves shall be used rather than a series of curves with varying radii and/or a series of short curves separated by short, straight segments.
- (4) There shall be a tangent of at least 100 feet between reverse curves for all streets other than local streets.
- (5) The center line of the street cartway shall correspond with the center line of the street right-of-way.
- (6) The minimum distance between curb face and an obstruction shall be 1.5 feet.
- (7) Proper sight distances shall be provided with respect to both horizontal and vertical alignment. See § 320-9.17 for sight distance requirements.
- (8) Proper super-elevation shall be provided for curves on arterial and collector streets, following standards of PennDOT or AASHTO.
- (9) See Table 2 Minimum Horizontal Curve Radius for determination of minimum horizontal centerline radius.

Table 2 Minimum Horizontal Curve Radius

Roadway Classifications	Minimum Centerline Radius (feet)
Local Street	150'
Collector Roads	300'
Arterial Roads	500' or as required by PennDOT

§320-3.25 PAVEMENT SECTIONS AND WIDENING

- A. The typical pavement sections for local, collector and arterial roads shall be as shown in the Typical Details section of Appendix B.
- B. Street widening.
 - (1) For pavement widening, all improvements shall be completed to the centerline of the existing cartway consistent with the design standards shown in the Typical Details section of the Appendix B.
 - (2) The Borough reserves the right to require improvements beyond the centerline if required for vertical or horizontal control, proper storm water management, or safety of vehicular or pedestrian traffic.
 - (3) Existing pavement shall be sawcut full depth a minimum of 1' from the existing edge of cartway, or to an acceptable pavement quality as determined by the Borough, whichever is greater.
 - (4) All paving joints shall receive an emulsified asphalt tack coat and paving fabric a minimum of 2' wide prior to placement of wearing course.
 - (5) A minimum 1½" deep and 5' wide paving notch shall be provided where new wearing course is to meet existing pavement.

§320-3.26 STREET INTERSECTIONS.

- A. No more than two streets shall intersect at the same point.
- B. The centerline of all streets shall intersect at right angles.
- C. Minimum separation.
 - (1) Intersections involving local streets and local streets shall not be located less than 100 feet apart on the same side of the street, measured from center line to center line, along the center line of the street.
 - (2) Intersections involving local streets and collector or arterial streets shall not be located less than 300 feet apart on the same side of the street, measured from center line to center line, along the center line of the collector or arterial street.

- (3) Intersections involving arterial or collector streets with arterial or collector streets shall not be located less than 800 feet apart on the same side of the street, measured from center line to center line, along the center line of the collector or arterial street.
- (4) Two streets intersecting from opposite sides shall intersect at their center lines, or their center lines shall be offset by a minimum of 200 feet.

D. Radius Returns.

- (1) When site conditions warrant, larger curb return radii shall be used. The curb returns at all intersections (both streets and driveways) shall be designed for the largest anticipated vehicle to turn without encroaching into the opposing lane.
- (2) The cartway edge at street intersections shall be rounded by a tangential arc with a minimum radii as follows:
 - (a) When a local street intersects with another local street, it shall have a twenty-foot curb return radius.
 - (b) When a local street intersects with a collector or arterial street, it shall have a thirty-foot curb return radius.
 - (c) When a street intersects with a PennDOT roadway, it shall have a curb return radius in accordance with PennDOT standards.

E. The right-of-way radii at intersections shall be substantially concentric with the edge of the cartway.

F. Where warranted by a traffic impact study or anticipated large vehicle sizes, Borough Council may require additional traffic lanes or additional right-of-way to facilitate vehicular turning movements at existing or proposed street intersections within, or adjacent to, proposed subdivisions or land developments.

G. Where applicable, an intersection may be designed with turning lanes or intermediate islands for channelization and will be reviewed and considered on a case by case basis. All designs shall be in accordance with the book entitled A Policy on Geometric Design of Highways and Streets (latest edition) by AASHTO or PennDOT standards.

H. Where applicable, traffic calming measures at intersections and crosswalks may be implemented for new local streets to protect pedestrians. All traffic calming measures shall be designed in accordance with PennDOT standards and approved by the Borough Council.

I. The developer shall furnish and install street name signs and traffic control signs at all street intersections as directed by Borough Council.

J. A 100-foot clear sight triangle easement or dedicated right-of-way shall be provided at all street to street intersections in accordance with §320-3.35.C(3).

§320-3.27 CUL-DE-SAC STREETS AND P-STREETS.

A. Permanent cul-de-sac streets or P-streets will not be approved when a through street is feasible.

- B. The length of the cul-de-sac street shall be measured from the centerline intersection with the through street to the center point of the turnaround.
- C. The length of the P-street street shall be measured from the centerline intersection with the through street to the farthest point on the P-street from the intersection with the through street.
- D. Permanent cul-de-sac streets or P-streets shall have a minimum length of 250 feet and shall not exceed 1,000 feet in length. Temporary cul-de-sac streets shall not have a minimum length.
- E. Cul-de-sac streets and P-streets shall be designed to serve a maximum of 50 dwelling units or units of occupancy for residential development and a maximum of 500 average daily vehicle trips based on the latest edition of Trip Generation Manual published by the Institute of Transportation Engineers for a non-residential development.
- F. Permanent cul-de-sac streets must be provided with a paved turnaround with a minimum diameter of 80 feet to the outside curb and of 100 feet to the street right-of-way line.
- G. All cul-de-sac streets shall be designed to provide an area for the deposit of snow by snowplow. If the cul-de-sac street is proposed for dedication to the Borough, the developer shall provide an easement for winter weather maintenance purposes if the area for depositing of snow is located outside of the street and turnaround right-of-way.
- H. Cul-de-sacs with a center island will not be accepted by the Borough.
- I. Dead-end streets shall be prohibited except when designed as temporary turnarounds to permit future street extension into adjoining tracts or when designed as cul-de-sac streets.
- J. Any street dead-ended for either access to an adjoining property or for authorized stage development which is greater than one lot depth shall be provided with a temporary all-weather turnaround within the subdivision or land development. The use of such turnaround shall be guaranteed to the public until such time as the street is extended. The temporary turnaround shall be circular with a minimum cartway radius of 25 feet and shall remain completely within the right-of-way.

§320-3.28 AUXILIARY LANES.

- A. The combination of speed, volumes, location and arrangement of driveways, and intersections may require the installation of turning lanes. When required by a traffic study, a turning lane of sufficient length and width shall be constructed to allow vehicles to safely enter or leave the development.
- B. Where the width of the street right-of-way is insufficient to permit the construction of a needed turning lane, the permittee shall provide any necessary additional right-of-way.
- C. When required, auxiliary lanes shall be constructed at no cost to the Borough.
- D. If an auxiliary lane must be located in front of another person's property, the applicant shall be required to secure the approval of the other person or indemnify the Borough against any action which the other person may bring against the Borough.

§320-3.29 ACCESS REQUIREMENTS.

- A. All subdivisions and land developments containing more than 50 dwelling units or units of occupancy or non-residential buildings containing, either singly or in combination, greater than 20,000 square feet of gross floor area shall be provided with at least two separate and distinct means of access for the subdivision or land development.
- (1) Where a single tract of land is subdivided into lots for subsequent development, all of the lots created by the initial subdivision shall be considered in determining whether there will be more than 50 dwelling units or units of occupancy or non-residential buildings containing, either singly or in combination, greater than 20,000 square feet of gross floor area.
 - (2) All development, whether existing or proposed, and all existing dwelling units or units of occupancy and buildings shall be considered in determining whether there will be more than 50 dwelling units or units of occupancy or nonresidential buildings containing, either singly or in combination, greater than 20,000 square feet of gross floor area.
 - (3) For the purpose of this section, all development indicated on subdivision and/or land development plans which have been submitted to the Borough and which are either pending approval or have been approved but not constructed shall be considered proposed development.
- B. Access may be provided through the location of two or more public or private streets, each of which intersects with an existing public through street. Such public or private streets shall meet all of the requirements of this chapter concerning design, number of access points and construction.
- C. Access for a land development may be provided through two or more access drives into the land development from an existing public street or private street meeting the requirements of this chapter, unless such access drives are prohibited by other provisions of this chapter. Such access drives shall be separated by a distance of at least 150 feet, unless a greater separation distance is required by this chapter or by any other law or regulation. The intersection of the access drive with the abutting street shall comply with all requirements of this chapter.
- D. If the applicant is unable to provide access to the subdivision or land development meeting the requirements of §320-3.28.A(1) or A(2) and, if applicable, has obtained a waiver from the requirements of §320-81, the applicant shall provide an emergency access.
- (1) The emergency access shall be improved in a manner that emergency vehicles may safely traverse the area. Borough Council may consider the recommendations of providers of emergency services within the Borough when determining the nature and extent of the improvements which are required. The area of the emergency access shall be clearly indicated on the plan.
 - (2) The applicant shall submit evidence that the emergency access design has been reviewed and approved by the providers of emergency services within the Borough. The applicant shall demonstrate that the emergency access will be accessible to emergency vehicles after completion of construction.

- (3) The emergency access may be located so that access to the subdivision or land development is gained from a public street at a location unsuitable for regular access with the existing public street.
- (4) The emergency access may be located so that access is gained from an adjoining tract. For example, a subdivision or land development adjoining a parking lot of another use may provide emergency access through a point with a break chain or other acceptable device. Applicants with plans indicating emergency access through an adjoining tract shall provide evidence that the adjoining property owner has irrevocably consented to such emergency access location.

§320-3.30 STATE HIGHWAYS.

All subdivisions and land developments which propose access or improvements to a state highway shall comply with all requirements of this chapter and with all applicable requirements of PennDOT. The developer shall obtain all necessary permits and approvals from PennDOT for the proposed access and/or improvement to the state highway.

§320-3.31 FEE IN LIEU OF IMPROVEMENTS.

Where this article requires certain street widening, and/or construction of sidewalks and curbs along a street, and the applicant requests a modification of the requirements, Borough Council may approve a fee-in-lieu of payment. Such fees shall only be used for streets, sidewalk, trail, curbing and stormwater management improvements within one mile of the subject property. The intent is to allow more comprehensive improvements of a street, as opposed to major improvements to a relatively small percentage of a street. The intent is to also allow transportation spending to be prioritized towards the segments most in need of improvements.

§320-3.32 DRIVEWAY CLASSIFICATIONS.

- A. The ability of a driveway to function safely and efficiently as an integral component of a street system requires that its design and construction be based on the amount and type of traffic that it is expected to serve and the type and character of street which it accesses. Driveways are separated into four classifications based on the amount of traffic they are expected to serve. A description of each classification and typical examples of land uses normally associated with each follows:
- (1) Minimum-Use Driveway. A driveway normally used by not more than 25 vehicles per day, such as:
 - (a) Single family detached and twin dwellings; or
 - (b) Apartments or townhouse structure with five units or less.
 - (2) Low-Volume Driveway. A driveway normally used by more than 25 vehicles per day, but less than 750 vehicles per day, serving uses such as:
 - (a) Office buildings;
 - (b) Schools; or

- (c) Car washes.
- (3) Medium-Volume Driveway. A driveway normally used by more than 750 vehicles, but less than 1500 vehicles per day, normally not requiring traffic signalization, serving uses such as:
 - (a) Motels and hotels;
 - (b) Fast food restaurants;
 - (c) Service stations and small shopping centers or plazas; or
 - (d) Schools.
- (4) High Volume Driveway. A driveway normally used by more than 1500 vehicles per day, often requiring traffic signalization, serving uses such as:
 - (a) Large shopping centers;
 - (b) Multi-building apartment or office complexes; or
 - (c) Large motels and hotels.
- B. Local Street. A driveway acting as a connecting link between two or more streets shall be, for the purpose of this article, considered a local street and not a driveway regardless of its ownership. As such, its design must be in accordance with the standards governing the design of local streets.

§320-3.33 LOCATION RESTRICTIONS FOR DRIVEWAYS.

- A. Driveways shall not be located where they would interfere with the placement and proper functioning of street signs, signals, detectors, lighting or other devices that affect traffic control. Driveways shall not be located within 150 feet of a signalized intersection.
- B. Driveways on a lot which abuts two or more intersecting streets may be restricted to only one street.
- C. Driveways shall access the street of lesser classification, unless specific site conditions warrant access to the higher classified street.
- D. No portion of any driveway shall be located outside of the property line of a lot. For the purpose of this section alone, as to lots which do not extend to the centerline of the abutting public street, the property line shall be extended, at right angles or radially from the public street right-of-way, to the centerline of the public street so that no portion of any driveway shall be located in front of an adjoining property.
- E. Driveways shall be located a minimum of three feet from the property line.
- F. The Borough may require the permittee to locate a driveway directly across from a street, or driveway on the opposite side of the street if it is judged necessary or advisable for safety purposes.

- G. Driveways not classified minimum use shall have a minimum of 125 feet centerline separation from all other streets and nonminimum use driveways.
- H. Driveways serving lots located adjacent to a street intersection are subject to the following standards:
 - (1) There shall be a minimum ten foot tangent distance between the intersecting street radius and the radius of the first permitted driveway.
 - (2) The distance from the edge of pavement (curbline) of the intersecting street to the radius of the first permitted driveway shall be a minimum of 30 feet for a local street and 40 feet for a collector street.
 - (3) Paragraphs (1) and (2) of this subsection may be modified only if the intersecting street radius extends along the lot frontage to the extent that compliance is physically impossible.
- I. Multiple driveways serving the same lot must be separated by a minimum distance of 15 feet measured along the street right-of-way line and 20 feet measured along the curb line. The number of driveways allowed for each property shall be in accordance with §320-3.33.B.
- J. All driveways shall be constructed so as not to impair drainage within the street right-of-way, alter the stability of the improved area or change the drainage of adjacent areas.
- K. A traffic impact study in accordance with Chapter 325, Subdivision and Land Development, shall be provided as part of an application for a high-volume driveway permit.

§320-3.34 DRIVEWAY DESIGN STANDARDS.

- A. Site Requirements.
 - (1) Driveways shall be designed for their intended function. Sufficient design information shall be submitted to indicate that the number of travel lanes and widths proposed have been designed to accommodate the anticipated traffic to and from the development.
 - (2) Applications for driveways providing access to uses which provide drive-in or drive-thru service shall, when requested, include information relative to the amount of storage provided between the service facility and the street right-of-way, the number of service operations anticipated during peak periods and the hours and days of operation.
 - (3) Driveways other than minimum use shall be designed and configured to prevent vehicles entering or exiting the site from backing out or stopping on the street or right-of-way.
 - (4) Driveway approaches shall be positioned at right angles (90°) to the street.
- B. Number of Driveways.
 - (1) The number and location of entrances which may be granted will be based on usage, interior and exterior traffic patterns and current design policy of the Borough.

- (2) Only one driveway shall be permitted for a single family residential lot and not more than two driveways shall be permitted for a multifamily or nonresidential lot.
- (3) If the property frontage exceeds 600 feet, the Borough may authorize an additional driveway.
- (4) Regardless of frontage, the development may be restricted to a single entrance/exit driveway.

C. Driveway Width, Radius Returns and Grade.

- (1) Driveway width and radius returns shall be as shown in the Typical Details section of Appendix B.
- (2) Driveway grade requirements in curbed and uncurbed streets shall conform to Figure F-1 Driveway Grade contained in Appendix B.

D. Driveway Pavement.

- (1) Minimum use – The first 10 feet of the driveway extending from the back of sidewalk or edge of cartway if no sidewalk is present shall be bituminous paving. The remaining portion of the driveway shall be stone or bituminous paving.
- (2) Driveways other than minimum use shall be bituminous paving.

§320-3.35 SHARED OR JOINT-USE DRIVEWAYS.

Shared or joint-use driveways must meet the following standards:

- A. Shared minimum use driveways shall be used only for two dwelling units.
- B. Shared or joint-use driveways other than minimum use shall be designed to local street standards.
- C. To decrease the potential for vehicular conflicts, driveways may be located either partially, centered on, or entirely on one lot.
- D. Joint use or shared driveways do not require a specific right-of-way or easement width.
- E. An easement agreement shall be provided and recorded that indicates the rights of ownership, access, and maintenance. The Borough is not responsible to settle conflict issues arising from joint or shared driveways.

§320-3.36 SIGHT DISTANCE.

- A. Sight distance requirements and measurements other than 100-foot clear sight triangle, shall be determined using the process that would apply under PennDOT regulations along a state road, even if a state road is not involved.
- B. Horizontal and Vertical Curve sight distance requirements and measurements shall be in accordance with PennDOT standards for sight distance as outlined in Design Manual - Part 2,

Highway Design (Publication 13), latest edition, and other applicable PennDOT requirements. Sufficient design and plan information shall be submitted with the plan application proving the minimum standard will be achieved.

- C. Sight distance measurements are required for the following:
- (1) Intersections - Sight distance shall be adequate to safely allow each permitted movement to be made into or out of the proposed street or driveway as described by PennDOT regulations.
 - (2) Horizontal Curves – The horizontal curve sight line is the chord of the curve, and the stopping sight distance is measured along the centerline of the inside lane around the curve.
 - (a) If the curve sight line extends beyond the street right-of-way, an easement or additional right-of-way will be required. No obstructions such as walls, cut slopes, buildings and possibly guide rail or other similar items shall be placed within this area.
 - (b) Vertical Curves - Minimum stopping sight distances shall be provided for all crest vertical curves.
 - (3) A 100-foot clear sight triangle easement or dedicated right-of-way shall be provided at all intersections of streets. Driveways do not require a clear sight triangle.
 - (a) The clear sight triangle easement or dedicated right-of-way, shall include the area on each street corner that is bounded by a line-of-sight of 100 feet, measured along the center line of each street from the point of intersection.
 - (b) Clear sight triangles shall be indicated on all plans, and a note shall be provided on all plans which states that “No structures, landscaping or grading may be constructed, installed, performed or maintained in the area of the clear sight triangle which shall exceed three feet in height or which may in any manner obscure the vision of motorists at such intersection.”
 - (c) Deeds to lots which contain clear sight triangles shall specifically include this restriction.

§320-3.37 SIGNAGE, UTILITIES, STRUCTURES AND OTHER ITEMS IN THE RIGHTS-OF-WAY.

- A. All street and traffic signs and pavement markings shall be consistent with PennDOT requirements and with the MUTCD with respect to type, height and location.
- B. All permanent objects shall be at least 18 inches behind face of curb. This includes, but is not limited to, items such as utility poles, sign posts, fire hydrants and trees.
- C. Utilities shall be installed behind curb when feasible.
- D. Manholes placed in the cartway should not be located in the wheel path of traveling vehicles.

- E. All structures in the street, including, but not limited to, manholes, gas valve boxes and water valve boxes, shall be 0 inch to 0.25 inch below the finished surface of the cartway and maintained in good working order. Owners of such structures shall be responsible for annual inspection and maintenance. If any deficiencies, including, but not limited to broken or missing valve tops or settlement around the structure, are found and not corrected by the owner or person responsible for such structures within 60 days' notice, the Borough shall proceed to do the work necessary and required to fix the structure and charge the owner of such structure the cost of the repair plus 20%.

ARTICLE III.C

APPLICATIONS FOR STREET AND DRIVEWAY APPROVALS

§320-3.51 PROCEDURE FOR SUBMISSION OF PLANS FOR STREETS.

All persons desiring to design or construct a new street or to widen or change an existing Borough street shall submit a subdivision or land development plan meeting all requirements of and following all procedures required by Chapter 325, Subdivision and Land Development, and Chapter 315, Stormwater Management. New streets and widening of existing Borough streets shall be permitted only as part of a subdivision or land development.

§320-3.52 DRIVEWAY PERMIT APPLICATIONS.

- A. The applicant for a driveway permit shall provide a properly completed Borough permit application form signed by the applicant. If the applicant is not the record owner of the property to be served by the driveway, the applicant shall present proof that the applicant has the permission of the record owner to file the application.
- B. The applicant for a driveway permit shall provide two sets of plans, of a quality sufficient for photocopying or scanning, detailing the location and pertinent dimensions of both the proposed installation and related roadway features.
- C. All applications shall be submitted at least 10 working days prior to the anticipated start of work. No work shall begin prior to the issuance of a permit.
- D. No application is complete without the required fee.
- E. The Permit Official shall determine if the proposed method of constructing or making said connection, as reflected on the application, will (A) minimize the adverse impact of stormwater runoff or surface drainage resulting from said connection, (B) not cause damage to the road to which the driveway is to be connected, and (C) not create or increase hazardous driving conditions for those persons using the road to which the driveway is to be connected.
- F. The Permit Official shall issue a driveway permit if the application meets the requirements of this chapter. If the plan is found deficient, or if in the opinion of the Permit Official the plan could be improved so as to (A) minimize the adverse effect of stormwater runoff, (B) lessen drainage to the public road to which the driveway is to be connected, or (C) lessen hazardous driving conditions on the road to which the driveway is to be connected (including provisions for a clear sight triangle), the Permit Official shall, by written communication to the applicant, notify him of the changes to be made. The applicant shall immediately make such changes and return the revised plan to the Borough. When such plan is in acceptable form, the Permit Official shall issue the permit.

§320-3.53 DRIVEWAY PLAN REQUIREMENTS.

- A. Minimum-Use Driveways. The permit application for all minimum-use driveways shall include a plan which illustrates, at a minimum, the following, including dimensions where applicable:
 - (1) Design features of existing and proposed driveways, curbs, tapers, and acceleration and deceleration lanes, including the following:

- (a) Driveway width.
 - (b) Driveway radii and other points of curvature.
 - (c) Driveway grade or profile and cross sections.
 - (d) Driveway angle relative to the roadway.
- (2) Distance from each existing and proposed driveway to the following:
- (a) Nearest street intersection.
 - (b) Nearest driveway on adjacent properties within the limits of the safe sight distance.
 - (c) Streets and driveways opposite the site and within the limits of the safe sight distance.
 - (d) Relevant property lines and property lines extended to the roadway.
- (3) Sight distance in each direction from each proposed driveway.
- (4) The number of vehicles per day which are expected to utilize each proposed driveway.

B. Driveways Other Than Minimum-Use. The permit application for all driveways other than those classified as minimum-use shall include a plan which illustrates, at a minimum, the following, including dimensions where applicable:

- (1) Existing roadway pavement, ditches, rights-of-way and relevant property lines, roadway appurtenances, utilities, medians and other significant features that may affect the location of the proposed driveway.
- (2) Existing and proposed buildings, including a description of present and proposed uses of buildings.
- (3) Details of internal traffic circulation, parking and traffic signs.
- (4) Design features of existing and proposed driveways, curbs, tapers, acceleration and deceleration lanes, including the following:
 - (a) Driveway width.
 - (b) Driveway radii and other points of curvature.
 - (c) Driveway grade or profile and cross sections.
 - (d) Driveway angle relative to the roadway.
 - (e) Dimensions of traffic islands adjacent to the roadway and within the development that separate traffic flow from or onto the roadway.

- (f) Driveway surface material and traffic island materials.
 - (g) Location of all required traffic control devices.
- (5) Distance from each existing and proposed driveway to the following:
- (a) Nearest street intersection.
 - (b) Nearest driveway on adjacent properties within the limits of the safe sight distance.
 - (c) Streets and driveways opposite the site and within the limits of the safe sight distance.
 - (d) Relevant property lines and property lines extended to the roadway.
 - (e) Building and business appurtenances on the site.
- (6) Sight distance in each direction from each proposed driveway.
- (7) The number of vehicles per day which are expected to utilize each proposed driveway.

§320-3.54 STORMWATER MANAGEMENT CONTROL PLAN.

Applicant shall simultaneously submit a stormwater management plan which shall comply with Chapter 315, Stormwater Management. No permit will be issued until the applicant has met the conditions of Chapter 315.

§320-3.55 TRAFFIC CONTROL DEVICES.

- A. Non-Electrically Powered Devices. The applicant shall identify all proposed non-electrically powered traffic control devices which are required to provide for the safe and orderly movement of vehicular or pedestrian traffic, or both. These devices shall include, but not be limited to, any required regulatory, warning or guide signs, delineators and pavement markings.
- B. Electrically Powered Devices.
- (1) When power-operated devices, including traffic signals, are required for proper traffic control, a traffic signal permit shall be obtained from PennDOT. The permit to own and operate a traffic control device may be requested by and issued only to the Borough. The applicant shall provide all information necessary to obtain such a permit and shall reimburse the Borough for all expenses involved in applying for and obtaining the permit, and in purchasing, constructing, installing, operating and maintaining such device.
 - (2) Applications for new streets or driveways that include traffic signal control shall be accompanied by the following additional information:
 - (a) An engineering study in sufficient detail to allow determination of the need for signal control and the adequacy of its design and operation.

- (b) Location of traffic signal heads, poles, controller and detectors.
 - (c) Phasing and timing diagrams in Penn DOT format.
- (3) Applicants proposing new traffic signals or modifications to existing traffic signals shall all install new equipment or upgrade all existing signal equipment to the current standards as required by PennDOT. Applicant shall install all improvements to cartways and other traffic control devices, including but not limited to cartway marking and signage, which PennDOT may require as part of the traffic signal permit.
- (4) Applicants shall post any financial security PennDOT requires.

ARTICLE III.D

ADMINISTRATION, DEDICATION AND ACCEPTANCE OF STREETS

§320-3.81 APPEALS AND REQUESTS FOR MODIFICATIONS.

All appeals or requests for modifications of provisions of this article shall be processed in accordance with the following:

- A. An appeal or request for a modification shall be submitted to the Borough. The request shall be made in writing and identify the following:
 - (1) The specific section of this article from which a modification is requested or a decision which is being appealed.
 - (2) The proposed alternative to the requirements, when applicable.
 - (3) Justifications for an approval of the modification or appeal.
- B. **Modification of Design Requirements** Upon application made, Borough Council may modify one or more requirements of this article where strict compliance with the terms of the article cannot reasonably be achieved and where each of the following is demonstrated by the applicant to the reasonable satisfaction of Borough Council:
 - (1) The applicant has done all that can reasonably be done to satisfy the design requirements.
 - (2) If additional land is required, the applicant provides satisfactory evidence that it cannot be purchased at a reasonable price.
 - (3) No traffic problem will be created as a result of the modification.
 - (4) The applicant executes an indemnity agreement satisfactory to the Borough.
- C. The provisions of this article are intended as minimum standards for the protection of public health, safety and welfare. Borough Council may grant a modification from literal compliance with mandatory provisions of this article if the applicant can demonstrate that an alternative proposal will allow for equal or better results.
- D. The approval of a modification or appeal shall not have the effect of making null and void the intent and purpose of this article. In the approval of a modification or appeal, the Borough Council may impose such conditions as will, in its judgment, secure substantially the objectives of the standards and requirements of this article.
- E. Any person aggrieved by any action of a Borough representative may appeal to Borough Council within thirty (30) days of the date of the action taken by the Borough representative.

§320-3.82 FINANCIAL SECURITY.

Financial security to secure completion of required improvements shall be calculated, posted, reduced and released in accordance with Chapter 325, Subdivision and Land Development, and the MPC.

Notwithstanding the foregoing, no financial security shall be finally released until the developer shall provide the Borough with:

- A. A certification from the contractor responsible for constructing the streets and stormwater management facilities that all construction conforms to Borough or PennDOT specifications.
- B. An as-built plan for the streets and related storm water management facilities in accordance with the requirements of Chapter 325 Subdivision and Land Development, and Chapter 260, Stormwater Management.

§320-3.83 DEDICATION AND ACCEPTANCE OF STREETS.

- A. Any Final Plan shall contain an offer to dedicate all streets unless Borough Council has approved the construction of private streets.
- B. Applications for acceptance of streets will only be considered between January 15 and August 1 in order to meet the submission deadline for Liquid Fuels Tax fund allocations for said streets.
- C. Borough Council will accept only those streets which have been constructed in accordance with specifications and requirements contained in this Chapter, Chapter 325, Subdivision and Land Development, and Appendix B.
- D. Any person who requests that Borough Council accept a street shall, at such person's sole cost and expense, provide the Borough with all information and plans necessary for the Borough to process the acceptance of dedication. The person requesting the Borough accept a street shall transfer good and marketable title for the street, free of all liens and encumbrances, to the Borough. The person requesting that the Borough accept dedication shall pay all costs associated with such acceptance, including but not limited to preparation of documents, recording costs, and costs for the preparation and advertising of the ordinances to accept the street and to impose traffic and parking regulations. Nothing in this chapter shall require the Borough to accept dedication of any street.
- E. With respect to a street through residential areas, when ninety (90%) percent of the lots or dwellings fronting on the street are occupied, or with respect to a street through commercial or industrial developments, when lots having ninety (90%) percent of the front footage have been occupied, and upon completion of the final punch list items, the applicant request the Borough accept the completed street.
- F. Notwithstanding final acceptance of the street or storm water management facility, the Applicant shall remain responsible for maintenance of the same, snow removal excepted, for a period of eighteen (18) months from the date of final acceptance, and the applicant shall post maintenance security with the Borough in the amount calculated in accordance with the MPC and Chapter 325, Subdivision and Land Development.

ARTICLE IV

SIDEWALKS AND CURBS

§320-4.01 CONSTRUCTION OF CURB AND SIDEWALK REQUIRED.

Every owner of real estate in the Borough along, adjacent to, or abutting on a public or private street is hereby required to lay out and construct, and permanently maintain, both a curb and a sidewalk along such street or streets except as follows.

- A. The abutting street is identified in §320-4.07. In such case, the owner of the real estate along, adjacent to or abutting a designated street is required to lay out and construct curb and/or sidewalk as designated in such section.
- B. Borough Council grants a waiver under this chapter or under Chapter 325, Subdivision and Land Development.

§320-4.02 CURB AND SIDEWALK CONSTRUCTION.

All curbs and all sidewalks shall be designed and constructed in accordance with all requirements of this article and the following:

- A. PennDOT Publication 408 or its successor publication.
- B. PennDOT Publication 72 or its successor publication.
- C. PennDOT specifications for ADA-accessible curb ramps, sidewalk and driveway aprons (Pub 72 Standards for Roadway Construction Standard RC-67M).
- D. The ADA.
- E. Chapter 325, Subdivision and Land Development.
- F. Technical Specifications and Standard Details in Appendix B.

§320-4.03 CURB.

- A. All curb shall be concrete. Vertical concrete curb shall have a 6 inch or 8 inch reveal. All curbs shall be designed and constructed as shown in Appendix B.
- B. The use of rolled concrete curb, macadam curb, or alternate materials is not permitted, except to match existing curb on adjacent properties and is subject to approval by the Permit Official.
- C. Curb ramps for handicapped persons shall be constructed at crosswalks in accordance with guidelines and criteria contained in Chapter 8, Pedestrian Facilities, of the PennDOT Design Manual, Roadway Construction Standard RC-67M or any such future publications or any regulations adopted by PennDOT. All curb ramps shall comply with the ADA.
- D. Where property abutting the right-of-way line could be used as a parking area, the permit may require curbing, permanent guiderail or bumper blocks to be constructed along the right-of-way line in order to prohibit vehicle encroachment upon the sidewalk area.

- E. Curbing shall be constructed in ten-foot lengths. A pre-molded expansion material having a minimum thickness of 1/4 inch shall be placed between sections of curved curb and at intervals of not more than 120 feet. Intermediate joints between ten-foot sections shall be formed of two layers of single-ply bituminous paper.
- F. The depressed curb at driveways shall be no higher than 1 1/2 inch above the street surface, unless a differing standard is required by PennDOT. The length of this depressed curb shall not exceed 35 feet without a safety island. This safety island shall not be less than 15 feet in length.
- G. Grates or other obstructions shall not be placed in the gutter in front of a depressed curb or curb ramp.

§320-4.04 SIDEWALK.

- A. All sidewalks shall be a minimum of 4 inches thick, with 4 inches stone base except in areas traversed by vehicles where it shall be 6 inches thick and reinforced. All sidewalks shall be constructed as shown in the Typical Details section of the Appendix B.
- B. Sidewalks shall have a minimum four feet of clear unobstructed width, except along collector and arterial streets and adjacent to shopping centers, public schools and public parks, where sidewalks shall have a minimum unobstructed width of five feet. If sidewalks are less than five feet in width, see standards under the ADA, which may require periodic wider areas for passing of wheelchairs.
- C. Sidewalks shall be located within the street right-of-way, a minimum of one foot from the right-of-way line unless the Borough approves an acceptable alternative.
- D. All sidewalk and curb ramps shall meet all current ADA and PennDOT Publication 72 Standards for Roadway Construction Standard RC-67M requirements. The location and ramp type should be shown on the plans. Provide a note to indicate that the contractor is responsible to install the curb ramps, sidewalk and driveway aprons to the latest ADA or PennDOT standards at the time of construction.
- E. The detectable warning surface for curb ramps within the public right-of-way shall be constructed from removable panels. The panel's manufacturer shall be as specified by the Borough. The panels shall be provided and installed according to the manufacturer's specifications and shall meet all applicable PennDOT and ADA requirements.

§320-4.05 PERMITS.

- A. No curb or sidewalk shall be laid out, constructed, reconstructed or materially repaired by any person unless a permit is obtained from the Permit Official.
- B. The applicant for a curb and/or sidewalk permit shall provide a properly completed Borough permit application form signed by the applicant. If the applicant is not the record owner of the property, the applicant shall present proof that the applicant has the permission of the record owner to file the application.
- C. All applications shall be submitted at least 10 working days prior to the anticipated start of work. No work shall begin prior to the issuance of a permit.
- D. No application is complete without the required fee.

- E. No permit shall be issued by the Permit Official until the person making application shall submit plans for approval showing the location, length, width, depth, grade and design of the proposed curb and sidewalk to be constructed or repaired. The plan shall also include all materials to be used for construction.
- F. All curbs and all sidewalks shall be designed and constructed in accordance with this chapter, including Appendix B.

§320-4.06 COMMENCEMENT OF WORK.

Where streets are added by ordinance to the list of designated streets, the property owners thereon shall commence work within 180 days of the date of enactment of such ordinance. Where such compliance would constitute a hardship for the property owner, said owner may make written application for an extension of time to Borough Council.

§320-4.07 DESIGNATED STREETS FOR CURBS AND SIDEWALKS.

The owners of real estate adjacent to the following streets shall not be required to lay out or construct curbs and/or sidewalks where the improvements is listed as “No”, unless curb and sidewalk construction is required under Chapter 325, Subdivision and Land Development, for a particular project:

Street	Side	From	To	Curb	Sidewalk
Allen Drive	Both	Glen Oaks Drive	Blue Ridge Drive	Yes	No
Ann Street	Both	Shenks Lane	End	No	No
Barbara Street	West	Wabank Road	Spring Drive	Yes	No
Bender Avenue	Both	Manor Avenue	End	No	No
Blue Ridge Drive	Both	Pilgrim Drive	Wabank Road	Yes	No
Breneman Avenue	Both	North George Street	High School Avenue	No	No
Briargate Place	Both	Laurelgate Place	Cul-de-sac	Yes	No
Broadlawn Circle	Both	Fresh Meadow Drive	End	Yes	No
Cedar Hurst Circle	Both	Saint Regis Lane	End	Yes	No
Cemetery Road	Both	Manor Avenue	Northern Borough municipal line	No	No
Circle Avenue	Both	Herr Avenue	Cul-de-sac	No	No
Colonial Avenue	Both	Western property line of 10 Colonial Avenue	End	No	No
Creek Drive	Both	Northeast corner of Tax Account No. 440- 67692-0- 0000 (Conestoga River)	Borough line	No	No
Creek Drive	Both	Pucillo Drive	Conestoga River	Yes	No
Crossland Pass	Both	South Duke Street	Eastern Borough municipal line	No	No
East Charlotte Street	South	North George Street	High School Avenue	Yes	No
East Cottage Avenue	North	Spring Drive	Barbara Street	Yes	No

Fresh Meadow Drive	Both	Pilgrim Drive	Blue Ridge Drive	Yes	No
Friends Lane	Both	Gable Park Road	Pilgrim Drive	Yes	No
Gable Park Road	East	Friends Lane	Millersville Pike	No	No
Gable Park Road	West	Friends Lane	Millersville Pike	Yes	No
Glen Oaks Drive	Both	Fresh Meadow Drive	Fresh Meadow Drive	Yes	No
Green Hills Drive	Both	Millersville Pike	Fresh Meadow Drive	Yes	No
Heisey Avenue	Both	Leaman Avenue	Wabank Road	No	No
High School Avenue	Both	Ann Street	East Charlotte Street	No	No
Kauffman Alley	Both	Landis Avenue	Kready Avenue	No	No
Kready Avenue	Both	North George Street	Herr Avenue	No	Yes
Laurelgate Place	Both	Crossland Pass	Cul-de-sac	Yes	No
Leaman Avenue	Both	Manor Avenue	Heisey Avenue	No	No
Locust Point Lane	Both	Green Hills Drive	End	Yes	No
Mary Street	Both	West Frederick Street	End	No	No
Millersville Road	West	Millersville Pike	Northern Borough municipal line	No	No
Millersville Road	East	Millersville Pike	Northern Borough municipal line	Yes	No
Millersville Road	East	Wabank Road	East Charlotte Street	Yes	No
Model Avenue	South	High School Avenue	North George Street	Yes	No
Murray Cross Way	Both	Crossland Pass	Eastern Borough municipal line	No	No
North Duke Street	West	West Frederick Street	143 North Duke Street	Yes	No
Oak Ridge Drive	Both	Saint Regis Lane	Blue Ridge Drive	Yes	No
Old Cove Lane	Both	Fresh Meadow Drive	End	Yes	No
Pilgrim Drive	Both	Millersville Pike	Wabank Road	Yes	No
Quaker Hills Road	Both	Pilgrim Drive	Allen Drive	Yes	No
Ridge Avenue	East	East Charlotte Street	Kready Avenue	No	No
Saint Regis Lane	Both	Pilgrim Drive	Glen Oaks Drive	Yes	No
Shertzer Lane	Both	South entrance food market	Borough line	No	No
Shertzer Lane	West	South entrance food market	Manor Avenue	No	No
South Duke Street	East	Crossland Pass	Borough line	No	No
Spring Drive	East	East Cottage Avenue	New Street	Yes	No
Stonegate Court	Both	Murray Cross Way	Cul-de-sac	Yes	No
Thorngate Place	Both	Murray Cross Way	Cul-de-sac	Yes	No
Timber Point Lane	Both	Pilgrim Drive	End	Yes	No
Village Green Lane	Both	Fresh Meadow Drive	Glen Oaks Drive	Yes	No
Wabank Road	Both	Millersville Road	Eastern borough municipal line	Yes	No
Wabank Road	East	Barbara Street	Manor Avenue	Yes	No
Walnut Lane	Both	Fresh Meadow Drive	End	Yes	No

West Frederick Street	South	North Duke Street	228 West Frederick Street	No	No
West Frederick Street	South	South Duke Street	North Duke Street	Yes	No
Windgate Court	Both	Crossland Pass	Cul-de-sac	Yes	No
				No	No

§320-4.08 MAINTENANCE.

The owner of the property on which the curb and/or sidewalk are located or adjacent to the street right-of-way in which the curb and/or sidewalk are located shall maintain all curbs and sidewalks now in existence or hereafter constructed kept in good repair and in safe and usable condition.

§320-4.09 SIDEWALK REPAIRS AND REPLACEMENT.

- A. A sidewalk shall have a continuous common surface without abrupt pitches in angle or interruption by cracks or breaks and shall be free of loose material and holes deeper than 1/2 inch and two inches in diameter. It shall be free of cracks or breaks creating edges of 3/4 inch or more in height, including curbs running parallel to the sidewalk unless such curb is 12 inches or more in height above the sidewalk and is equipped with a handrail or guardrail. Cracks in sidewalks shall be no wider than 3/4 inch.
- B. Where an existing sidewalk is removed and replaced with a new sidewalk, such new sidewalk shall be installed in accordance with all standards set forth in this article. Where there is inadequate right-of-way or existing features prevent installation of sidewalks meeting the requirements of this article, such replacement sidewalks shall have a minimum width of four feet. If the landowner demonstrates to the satisfaction of Borough Council that it is not possible to install a sidewalk with a minimum width of four feet, Borough Council may grant a waiver to install a sidewalk of lesser width.
- C. Defects in existing sidewalks shall be corrected as soon as they appear. Small defects or repairs to small areas may be corrected with concrete, asphalt, grout or other material suitable for restoring the surface to a safe and usable condition. Should more than 20% of the length of the sidewalk in front of any individual property not be in good repair or safe and usable condition, the entire sidewalk shall be replaced if the existing sidewalk is not at approved grade in accordance with standards and elevations approved by the Permit Official. Replacement sidewalks shall be installed in accordance with this article.
- D. Sidewalks along Manor Avenue from Leaman Avenue to Route 741 shall be installed in accordance with all standards set forth in this article, except as provided in this subsection. Sidewalks may be a minimum of three feet in width, provided that all requirements of the ADA, including but not limited to providing sufficient areas for passing and turning, are met and a grass strip with a minimum width of two feet is maintained between the sidewalk and the curb.

§320-4.10 CURB REPAIRS AND REPLACEMENT.

- A. Curbs shall be maintained free of crumbling, settling or tipping. Deviations in horizontal alignment shall not exceed one inch in both vertical and rolled curbs. Spalling, crumbling or other deteriorations of the surface shall not exceed one inch in depth, and vertical alignments shall be

within two inches of perpendicular. Adjacent sections shall not be more than 3/4 inch out of vertical alignment.

- B. Curbs shall be repaired with cement, grout, concrete or other material suitable for restoring to a safe and functional condition. Methods of repair may include the use of vertical pins and new concrete when the top sections are deteriorated. Whenever more than 20% of the curb needs to be repaired and is not at current approved elevation, it shall be replaced in accordance with all requirements of this article.

§320-4.11 INSPECTIONS.

The Permit Official may make or cause to be made periodic inspections of curbs and sidewalks in the Borough. Inspections shall also be made when complaints are received. If curbs and sidewalks are found to be deficient according to the standards enumerated in this article, the property owner shall be notified in accordance with this article.

§320-4.12 OBSTRUCTIONS TO SIDEWALKS.

- A. All obstructions to the free use of sidewalks must be removed or corrected. Obstructions in the sidewalks such as curb shutoff valves, sewer vents and expansion joint material shall not project above or below the walk more than 3/4 inch. Broken covers and caps shall be replaced and secured.
- B. Signs along and over sidewalks must be at least eight feet above the surface of the sidewalk. Signs must not obstruct the pathway for persons using the sidewalks or adjacent to the owner's property.
- C. Trees and shrubbery and other vegetation overhanging any sidewalk. The owner of the property shall trim branches from any tree overhanging in any sidewalk adjacent to the property in the Borough so that there will be a clear height of eight feet above the surface of the sidewalk on or adjacent to the owner's property. Branches of any shrubs, trees or other form of vegetation shall be trimmed to permit an unobstructed pathway for persons using the sidewalks on or adjacent to the owner's property.

§320-4.13 ACTION UPON FAILURE TO COMPLY; VIOLATIONS AND PENALTIES.

- A. Upon neglect of any property owner to comply with any provision of this article, the Borough may, after 30 days' notice, have the laying out, grading, constructing or repairing of curbs and sidewalks done by the Borough. The cost of that work, plus 10% additional, together with all charges and expenses, shall be assessed against that property owner and may be collected by municipal claim and/or action in *assumpsit*.
- B. Any person who shall violate any provision of this article shall, upon conviction thereof, be sentenced to pay a fine of not more than \$1000 plus costs, including the Borough's reasonable attorneys' fees. After receiving notice of any violation, each day thereafter shall constitute a separate offense until the violation is remedied; and provided, further, that the penalties prescribed in this subsection may be in addition to any amount assessed and collected under §320-4.13.
- C. The penalties and remedies set forth in this article are in addition to and not in lieu of any fines, penalties or remedies authorized under the law. The existence or exercise of any remedy under this article shall not prevent the Borough from exercising any other remedy provided under this article or under any other Borough ordinance.

§320-4.14 NOTICES.

All notices required by this article shall be served on the owner of the premises to which the notice refers if such owner is a resident of the Borough. If the owner is not a resident, then the notice may be served upon the agent or tenant of the owner or upon the occupant of such premises. If the owner has no agent or tenant or there is no occupier of such premises, then service shall be by notice posted upon the premises and mailed to the last known address of the owner.

ARTICLE V
GENERAL CONDITIONS FOR PERMITS AND CONSTRUCTION

§320-5.01 CONSTRUCTION IN ACCORDANCE WITH PLANS AND REQUIREMENTS.

All facilities shall be constructed in strict accordance with the approved plans and no changes shall be made without prior written authorization of the Permit Official. Notwithstanding the provisions of this Section, the Borough reserves the right to require changes during the construction stages where field conditions warrant such changes. All construction shall be in accordance with PennDOT Form 408 Specification or as revised by Appendix B.

§320-5.02 PRE-CONSTRUCTION MEETING.

Prior to the commencement of construction, the permittee shall contact the Permit Official to arrange a pre-construction meeting. The permittee, his agents and contractor(s) shall attend the pre-construction meeting to review the Borough's construction requirements and inspection procedures.

§320-5.03 INSPECTIONS.

- A. All work done pursuant to the provisions of this chapter shall be inspected by the Permit Official. The permittee shall pay the costs of such inspections, observation and tests.
- B. The applicant shall notify the Permit Official two working days in advance of when the opening or excavation will be ready for backfilling and before commencing any backfilling.
- C. New and reconstructed streets. The permittee shall notify the Permit Official two working days in advance of the intended date of construction. The permittee shall make available one loaded tandem dump truck to proof roll the subgrade or base. The Borough, at the permittee's expense, reserves the right to require testing of the street materials to determine if the street construction complies in all respects with the approved plans, as modified. The inspection schedule for new and reconstructed streets shall be:
 - (1) Any street or road started and not completed must be inspected by Borough officials before work is renewed.
 - (2) After completion of subgrade and prior to placing any base material.
 - (3) Upon completion of base course.
 - (4) Upon completion of binder course.
 - (5) Upon completing of wearing course.
 - (6) A final inspection of all items of work shall be completed not more than 10 working days prior to requesting that the Borough accept dedication of the street.
- D. Curb and Sidewalk Construction or Repair. The permittee shall notify the Permit Official two working days in advance of construction or repair of a curb and sidewalk.
 - (1) The Permit Official may review both curblines and curb grade prior to actual construction.

- (2) The Permit Official may review the sidewalk forms prior to actual construction.
- E. The Borough reserves the right to make periodic inspections of construction. This section does not mandate periodic inspections, and the undertaking of periodic inspections shall not be construed as an acceptance of the work during construction or as a final inspection of the construction.
- F. Upon completion of all the public improvements, the permittee shall request the final inspection of the project. The final inspection shall be made by the Permit Official in conjunction with the permittee's contractor. Upon completion of the final inspection, the Borough shall provide the permittee with a final "punch list" of the defective items which must be repaired or replaced to meet Borough standards. No public facilities shall be offered to the Borough for acceptance of dedication until all punch list items have been satisfied.
- G. Any street, curb or sidewalk which is not inspected or does not meet Borough specifications will not be accepted by the Borough. The Borough has no obligation to accept any streets, curbs or sidewalks.

§320-5.04 PERMITTEE RESPONSIBILITIES.

- A. The permittee shall pay all fees, costs and expenses incident to or arising from the project, including the cost of related street improvements which increased traffic or stormwater may necessitate. The permittee shall reimburse the Borough for any and all inspection costs within 30 days after receipt of the Borough's invoice.
- B. The permittee shall make available 24 hours a day a maintenance crew for repairs and maintenance of trenches or other work which has become hazardous to the public as a result of trench settlement or other reasons. The permittee shall make the name, address and telephone number of a responsible maintenance person available to the Borough. If the maintenance person so assigned fails to respond or the permittee fails to make repairs within the time frame directed by the Borough, then the necessary repairs or maintenance may be performed by the Borough and the full cost of the work charged to the permittee.
- C. The permittee shall be responsible to visually document the existing conditions of the street subject to excavation and the surrounding areas prior to the commencement of the excavation. Documentation of the area subject to excavation shall be in the form of photographs and/or video. It will be the permittee's responsibility to defend any claims of damage filed by the Borough or other affected party.
- D. In the event of failure or neglect by permittee to perform and comply with the permit or these regulations, the Borough may immediately revoke and annul the permit and order and direct the permittee to remove any or all structures, equipment or property belonging to the permittee or its contractors from the legal limits of the street right-of-way and to restore the right-of-way to its former condition.
- E. In the event the Borough determines that such structures, equipment or property pose a threat to the public safety, and the permittee fails to remove the same after notice from the Borough to do so, the Borough may perform the necessary and required work and shall be reimbursed for the costs thereof by the permittee within 30 days after receipt of the Borough's invoice.

- F. If work is stopped on a project for any reason, and if any ditch or trench, in the opinion of the Permit Official, remains open and unprotected, the permittee, if so directed, shall refill the ditch or trench and work shall not be resumed until the permittee is prepared to proceed immediately with the work to its completion. In the event the permittee fails to refill the ditch or trench or complete the work upon notice from the Permit Official to do so, the Borough may perform the necessary and required work and shall be reimbursed for the costs by the permittee within 30 days after receipt of the Borough's invoice.
- G. If the permittee, after making an opening in the surface for any other purpose, fails to restore any portion of the street or sidewalk to conform with the requirements of this chapter upon notice from the Borough to do so, the Borough may perform the work and the permittee shall reimburse the Borough for the costs within 30 days after receipt of the Borough's invoice.
- H. The Borough shall be provided with a copy of all tickets for materials used in the construction of proposed public streets or stormwater management facilities.
- I. At the time of delivery of the manufactured materials, the permittee shall provide the Borough with a statement of certification from the manufacturer that the manufactured materials to be used as part of the construction of the public improvement meet the minimum requirements of the appropriate Borough or PennDOT specifications.

§320-5.05 SPECIAL PROVISIONS.

- A. Notwithstanding the provisions of this chapter, Borough Council reserves the right and privilege to alter the design specifications, method of construction, type of construction and to require the utilization of a specific alternate for pavement construction where such alteration is based upon sound engineering judgment and principles and is in the best interest of the public.
- B. The permittee shall submit to the Borough a certificate or certificates of insurance for public liability. The type and amount of insurance shall be as specified in Appendix B.
- C. The permittee, his agent or contractor shall submit to the Borough proof that the contractor has workers' compensation insurance or that such contractor is not required to maintain workers' compensation insurance.

§320-5.06 STORMWATER MANAGEMENT FACILITIES.

- A. Altering existing stormwater management facilities is prohibited. Unless specifically authorized by the permit, the permittee shall not:
 - (1) Alter the existing stormwater drainage pattern or the existing flow of stormwater water.
 - (2) Direct additional stormwater onto or into the right-of-way in a way which would have a detrimental effect on the street or street facilities.
- B. When the work performed by the permittee interferes with the established stormwater management system of any street, the permittee shall make adequate provision to provide proper drainage to the satisfaction of the Borough.

§320-5.07 MAINTENANCE AND PROTECTION OF TRAFFIC.

- A. The Borough may require the permittee to submit a traffic control plan if it is anticipated that a potential hazard or interference with vehicular or pedestrian traffic will result from performance of the work.
- B. In accordance with, and in addition to Appendix B, during excavation or other construction in any street, every necessary and reasonable precaution shall be taken by the permittee and the parties performing the work to keep the street in a safe and passable condition, both day and night.
- C. Maintenance and protection of traffic shall be carried out in accordance with the most current applicable PennDOT Work Zone Traffic Control requirements.
- D. The traffic control plan shall be either:
 - (1) A detailed drawing, showing all traffic control devices; or
 - (2) A reference to a standard drawing set by PennDOT, provided that the referenced standard drawing properly depicts the work area and completely addresses the needed traffic control.
- E. Permittee shall furnish, erect, place and maintain traffic control signs and devices. Permittee shall maintain traffic during hours of construction and at all other times in accordance with the methods indicated on the traffic control plan and the following:
 - (1) Penn DOT Pub. 35, Approved Construction Materials (Bulletin 15).
 - (2) PennDOT Publication 72m.
 - (3) PennDOT Publication 111m.
 - (4) PennDOT Publication 212 Official Traffic Control Devices, Sub Chapter E.
 - (5) PennDOT Publication 213, Temporary Traffic Control Guidelines.
 - (6) PennDOT Publication 236.
 - (7) PennDOT Publication No. 408, Specifications.
 - (8) The MUTCD.
- F. A traffic control plan shall be submitted to and approved by the Permit Official before closing any portion of a lane to vehicular traffic.
- G. When a driveway is ready for use, the permittee shall, at the permittee's sole cost, install such traffic control devices as are necessary, in the discretion of the Permit Official, for public safety.

§320-5.08 TRAFFIC CONTROL DEVICES.

- A. Non-Electrically Powered Devices. The permittee shall, at its own expense, install and maintain all non-electrically powered traffic control devices, as specified in the permit, which are required

to provide for the safe and orderly movement of vehicular or pedestrian traffic, or both. These devices shall include, but not be limited to, any required regulatory, warning or guide signs, delineators and pavement markings.

- B. Electrically Powered Devices. The permittee shall install new equipment or upgrade all existing signal equipment in accordance with any traffic signal permit PennDOT has issued.
- C. All permanent sign installations within the street right-of-way shall be subject to approval of the Borough.

§320-5.09 RESTORATION OF SLOPES.

The permittee shall be responsible to restore all disturbed slopes or earthen areas to their original condition, or in a manner approved by the Borough.

§320-5.10 DEPOSIT OF MATERIALS.

- A. The permittee shall keep the improved area free of all material which may be deposited by vehicles traveling upon or entering onto the street during the performance of work authorized by the permit.
- B. The permittee shall be responsible for controlling dust conditions created by its operations.
- C. All excess material and material that is not suitable for backfill shall be removed and disposed of outside the street right-of-way as the work progresses.
- D. All retained material shall be placed or stored outside the improved area, and in such a manner that there will be no interference with the flow of water in any gutter, drain, pipe, culvert, ditch or waterway.

§320-5.11 EQUIPMENT DAMAGING ROADWAY.

- A. To protect the pavement and shoulders, all equipment shall have rubber wheels or runners and shall have rubber, wood or similar protective pads between the outriggers and the surface, unless otherwise authorized by the permit.
- B. In the event that other than rubber-equipped machinery is authorized for use, the pavement and shoulders shall be protected by the use of matting, wood or other suitable protective material having a minimum thickness of four inches.
- C. If the equipment damages the pavement, the permittee shall restore the pavement to its former condition, at the permittee's expense.

§320-5.12 RESTORATION.

The permittee shall be responsible to restore all disturbed portions of the street, including slopes, and all appurtenances and structures such as guiderails or drain pipes to a condition at least equal to that which existed before the start of any work authorized by the permit. This includes providing appropriate end treatments on guiderail systems where existing guiderail is being broken by the new street or driveway.

§320-5.13 ACCEPTANCE OF WORK.

Final acceptance of the work shall be made by the Permit Official after any necessary consultation with the Borough Engineer.

§320-5.14 CORRECTION OF UNSATISFACTORY OR INCOMPLETE WORK.

- A. In the event that any work performed by or for a permittee shall, in the opinion of the Permit Official or Borough Engineer, be unsatisfactory and the same shall not be corrected in accordance with their instructions within the time fixed by them or, in the event that the work for which the permit was granted is not completed within the time noted on the permit, the Borough may proceed to correct such unsatisfactory work or complete any such work not completed and charge the cost thereof, plus 20%, to the permittee.
- B. In case any dispute arises between the permittee and the Permit Official, the Permit Official shall have the authority to suspend work until the question at issue can be referred to and be decided by the Borough Council.
- C. When any earth, gravel, or other excavated material is caused to roll, flow, or wash upon any street, the permittee shall cause the same to be removed from the street within 24 hours after deposit. In the event the earth, gravel, or other excavated material so deposited is not removed, the Borough shall cause the removal, and the cost incurred shall be paid by the permittee.
- D. If within 18 months after the restoration of the surface as herein provided, defects shall appear therein resulting from defective backfilling by the permittee or its contractor or otherwise related to the Permittee's work, the Borough may proceed to correct such unsatisfactory work and charge the cost thereof, plus 20%, to the permittee.
- E. Payment for all work done by the Borough under the provisions hereof shall be made by the person made liable therefore within 30 days after a bill is sent to such person by the Borough. Upon failure to pay such charges within such time, the same shall be collectible by the Borough by an action at law or in the manner provided by law for the collection of municipal claims.

§320-5.15 ADDITIONAL RESTRICTIONS.

All work authorized by the permit shall be subject to all applicable laws, rules, and regulations, including, but not limited to the following:

- A. Act of October 26, 1972, P.L. 1017, No. 247, 53 P.S. §1611, concerning environmental control measures related to pollution and the preservation of public natural resources.
- B. Act of December 10, 1974, P.L. 852, No. 287, 73 P.S. §§176—182, concerning protection of the public health and safety by preventing excavation or demolition work from damaging underground utility facilities.
- C. OSHA. construction safety and health regulations, 39 Fed. Reg. 22801 (June 24, 1974) and 29 CFR §1926.1 et seq.
- D. Borough Ordinances which contain more stringent minimum safety requirements than this chapter.

§320-5.16 AS-BUILT PLAN OF UNDERGROUND FACILITIES AND STRUCTURES.

Within 60 days after completion of installation of any pipe, conduit or other underground structure under any Borough street or sidewalk by any party other than a Borough employee or contractor (acting under Borough authority), the applicant for the permit authorizing such work shall file or procure the filing showing the exact size, location and depth of the underground facilities or structures, with tie-in measurements to enduring surface monuments, accompanied by a certificate by the applicant or his/her contractor that the installation, as actually made, was in conformity with the location and any other specifications prescribed by the permit.

§320-5.17 EXPIRATION OF PERMITS.

Unless otherwise provided by the chapter or applicable law, any permits issued under this chapter shall expire one year after the date of issuance. Notwithstanding the foregoing, a permit may be conditioned upon completion of the authorized construction in a shorter time period.

- A. A permittee may apply for an extension of time to complete work authorized by a permit. Such application shall be made prior to the expiration of the permit. The permittee shall provide justification for the failure to complete the work within one year.
- B. No request for an extension of time is complete without the required fee.
- C. An expired permit cannot be extended.

§320-5.18 NOTICE OF COMPLETION OF WORK AUTHORIZED BY A PERMIT.

The permittee shall notify the Borough when all work authorized by the permit has been completed to enable a final inspection. Failure to provide notice of completion is a violation of this article.

§320-5.19 VIOLATIONS, PENALTIES AND REMEDIES.

- A. Any person who shall violate any provision of this article shall, upon conviction thereof, be sentenced to pay a fine of not less than \$100 and more than \$1000 plus costs, including the Borough's reasonable attorneys' fees. Each day that a violation continues and each section violated shall constitute a separate offense.
- B. The penalties and remedies set forth in this article are in addition to and not in lieu of any fines, penalties or remedies authorized under law.
- C. The Borough may enforce this article in equity.

ARTICLE VI

SMALL WIRELESS FACILITIES DEPLOYMENT

§320-6.01 SHORT TITLE.

This article shall be known and may be cited as The Millersville Borough Small Wireless Facilities and Use of Public Street Right-of-Way Ordinance.

§320-6.02 LEGISLATIVE INTENT.

Borough Council enacts this article to govern use of public street rights-of-way and municipal poles in accordance with and as limited by Act 50 of 2021, The Small Wireless Facilities Deployment Act. Borough Council recognizes the limitations of the Act on its powers and desires to regulate the public street rights-of-way and municipal poles to the maximum extent allowed by such Act. Borough Council further desires to limit, to the extent legally permissible, conflicts with other uses of the public street rights-of-way.

§320-6.03 DEFINITIONS.

In addition to the definitions in Article I of this Chapter, all words and phrases not otherwise defined herein shall have the meanings set forth in Section 2 of the Small Wireless Facilities Deployment Act, the Act of June 30, 2021, P. L. 232, No. 50, 53 P.S. §11704.1 et seq., and as may be amended in the future. In interpreting this article the following terms shall have the meanings set forth below:

CODE ENFORCEMENT OFFICER – The person designated by Borough Council to administer this article.

FCC – The Federal Communications Commission or any agency successor thereto.

ONE CALL – The Pennsylvania One Call Act, the Act of December 10, 1974, P. L. 852, as amended, 73 P.S. §176 et seq., and all regulations adopted to implement such statute.

§320-6.04 PERMIT APPLICATION REQUIREMENTS.

All persons who desire to install a small wireless facility within a right-of-way, whether by co-location or by the installation of a new utility pole, shall file an application in writing for a permit with the Code Enforcement Officer. In order to be considered a complete application, such application must include all of the following:

- A. A written application form identifying in detail the name of the applicant and contact information for the applicant and the name and contact information of the person who prepared the application and whether applicant proposes erection of a new utility pole or co-location on an existing utility pole.
- B. Precise location of all portions of the proposed small wireless facility, including pole mounted and ground mounted small wireless facility components.
- C. Identity of the owner of the utility pole if the applicant proposes co-location on an existing utility pole.
- D. A report by a qualified engineering expert which shows that the small wireless facility will comply

with all applicable FCC regulations. The report must identify the person who prepared the report and his or her qualifications.

- E. Construction drawings and supplemental information demonstrating compliance with Section 3 of the Act, the UCC (including as applicable a complete UCC permit application) and this article.
- F. Plan showing the proposed small wireless facility installation sealed by a professional engineer which shall contain a certification that after installation of the facility any sidewalk, curb, or curb cuts which may be impacted will comply with the ADA after installation of the small wireless facility. The plan shall meet all of the following requirements and include all of the following information:
 - 1. Existing right-of-way width, sidewalk, curbing, and cartway with sufficient information to demonstrate that the small wireless facility will be located completely within the existing public street right-of-way and will not interfere with the safe operation of traffic control equipment, sight lines, or clear zones for vehicles or pedestrians.
 - 2. Location of all storm water management facilities within the public street right-of-way including swales, inlets, rain gardens, and pipes, with sufficient information to demonstrate that the small wireless facility will be located and installed in a manner that will not interfere with existing storm water management facilities.
 - 3. Location of all utility facilities within the public street right-of-way including but not limited to public water and sewer facilities, including all hydrants and manholes with sufficient information to demonstrate that the small wireless facility will be located and installed in a manner that will not interfere with existing utility facilities.
 - 4. Location of any driveway, mailbox, or utility serving the abutting property.
- G. Where the application proposes co-location on an existing utility pole which is not a municipal pole, written permission from the owner of the existing utility pole.
- H. Where the application proposes installation of a new utility pole, a self-certification that the applicant has determined in good faith that it cannot meet its service reliability and functional objectives of the application by co-locating on an existing utility pole or municipal pole. This self-certification shall include documentation of the basis of the determination which shall identify all existing utility poles and municipal poles in the vicinity and why they are not suitable.
- I. Where a new pole or excavation for any reason is proposed, an application for a street opening permit meeting all requirements of Article II of this Chapter with street opening permit fee and evidence of compliance with One Call.
- J. The fee established by this article.

§320-6.05 TIME AND MANNER OF SUBMISSION OF APPLICATIONS.

All applications shall be submitted to the Borough office on a day that the Borough office is open to the public and during hours that the office is open to the public. Applications received within one hour of close of business shall be considered filed on the next day that the Borough office is open for business.

§320-6.06 CONSIDERATION OF APPLICATION AND ISSUANCE OF PERMIT.

The Code Enforcement Officer shall review the application for completion within the time periods required by the Act and, if incomplete, shall notify the applicant in accordance with the Act. The Code Enforcement Officer shall review and act upon the application in accordance with the Act.

- A. If the application meets all requirements of the Act and this article, the Code Enforcement Officer shall issue a permit to authorize installation of the small wireless facility and an invoice for the right-of-way fee for the small wireless facility.
- B. The proposed collocation, the modification or replacement of a utility pole or the installation of a new utility pole with small wireless facilities attached for which a permit is granted under this Article shall be completed within one year of the permit issuance date.
- C. Subject to the permit requirements and the wireless provider's right to terminate at any time, the permit shall grant the wireless provider authorization to operate and maintain small wireless facilities and any associated equipment on the utility pole covered by the permit for a period of five years, which shall be renewed for two additional five-year periods if the permit holder is in compliance with the criteria set forth in this article and the Act and the permit holder has obtained all necessary consent from the utility pole owner.

§320-6.07 DESIGN STANDARDS FOR SMALL WIRELESS COMMUNICATIONS FACILITIES.

All small wireless facilities to be installed and maintained within the right-of-way shall meet all of the following requirements:

- A. The small wireless facility and all associated equipment shall meet the size limits and height limits of the Act.
- B. The small wireless facility shall be located so as not to cause any physical or visual obstruction to pedestrian or vehicular traffic, or to otherwise create safety hazards to pedestrians and/or motorists or to otherwise inconvenience public use of the right-of-way. This shall include, but not be limited to, any interference with compliance with the ADA.
- C. A new pole shall not be located within 10 feet of an existing driveway or street intersection. A new pole shall not be located within any storm water management facility including, but not limited to, any swale or rain garden. A new pole shall not be located within 18 inches of the face of the curb.
- D. All equipment of the small wireless facility which is mounted on a pole shall have a clearance of not less than 18 feet if located over a cartway and not less than 10 feet if not located over a cartway.
- E. Ground-mounted accessory equipment, walls, or landscaping shall not be located within any storm water management facility including, but not limited to, any swale or rain garden or within 18 inches of the face of the curb.
- F. A new pole or ground mounted accessory equipment, walls or landscaping shall not be located an easement extending onto the lot adjoining the right-of-way without the written permission of the easement holder.
- G. Ground-mounted accessory equipment that cannot be placed underground shall be screened, to the fullest extent possible, through the use of landscaping or other decorative features. Any required

electrical meter cabinets shall be screened to blend in with the surrounding area. Ground-mounted accessory equipment shall not interfere with access to any driveway or mailbox.

- H. All underground facilities shall be designed and installed in a manner which will not require the removal or relocation of any storm water management facility or underground utility.

§320-6.08 MAINTENANCE OF SMALL WIRELESS FACILITIES.

The wireless provider shall maintain the small wireless facility in a manner that meets or exceeds all of the design standards of this article and all standards of the UCC. If the small wireless facility is the only facility on a pole, the wireless provider shall maintain the pole in accordance with this article and all applicable requirements. The wireless provider shall remove any graffiti on the small wireless facility, including but not limited to ground-mount accessory equipment, within 30 days after notice from the Borough to do so.

§320-6.09 DAMAGE TO EXISTING FACILITIES AND INDEMNIFICATION.

- A. A wireless provider shall repair all damage to the right-of-way or any other land so disturbed, directly caused by the activities of the wireless provider or the wireless provider's contractors, including installation of the small wireless facility or the failure to properly maintain the small wireless facility, and return the right-of-way in as good of condition as it existed prior to any work being done in the right-of-way by the wireless provider or damage resulting from the failure to maintain the small wireless facility. If the wireless provider fails to make the repairs required by the Borough within 30 days after written notice, the Borough may perform those repairs and charge the wireless provider the reasonable, documented cost of the repairs plus a penalty of \$500. The wireless provider who has failed to make the required repairs shall not be eligible to receive a new permit from the Borough until the wireless provider has paid the amount assessed for the repair costs and the assessed penalty or deposited the amount assessed for the repair costs and the assessed penalty in escrow pending an adjudication of the merits of the dispute by a court of competent jurisdiction.
- B. A wireless provider shall fully indemnify and hold the Borough and its officers, employees and agents harmless against any claims, lawsuits, judgments, costs, liens, expenses or fees or any other damages caused by the act, error or omission of the wireless provider or its officers, agents, employees, directors, contractors or subcontractors while installing, repairing or maintaining small wireless facilities or utility poles within the right-of-way.

§320-6.10 ANNUAL RIGHT-OF-WAY FEE.

In accordance with Section 3(c) of the Act, the Borough hereby imposes an annual fee for the use of right-of-way in the amount of \$270 per small wireless facility or \$270 per new utility pole with a small wireless facility. The annual fee shall become effective beginning on January 1, 2022, and shall be imposed for each calendar year or portion thereof during which a small wireless facility is located in a right-of-way. The owner of each small wireless facility installed within the Borough shall be responsible to pay such right-of-way fee whether or not such provider receives an invoice from the Borough. The fee will be due by January 31 of the calendar year for the calendar year to which the fee relates.

- A. The failure to pay the annual right-of-way fee shall be a violation of this article and shall be subject to the penalties and remedies in this article.
- B. If the annual right-of-way fee is not paid in full by January 31 of the calendar year, a penalty of ten (10%) percent of the annual fee shall be added. If the annual fee plus penalty is not paid in full by

March 31 of the calendar year, interest at the rate of one (1%) percent per month shall continue until the annual right-of-way fee, penalty, and interest are paid in full.

- C. The annual fee shall be adjusted upward by resolution of Borough Council if authorized by Section 7(c) of the Act.
- D. The owner of each small wireless facility installed within a right-of-way on the effective date of this article shall provide the Borough with a report identifying each existing small wireless facility identifying the location of such small wireless facility, the dimensions of such small wireless facility, and the date of installation of the small wireless facility. This report shall include the name and contact information for the owner of the small wireless facilities, including the address to send invoices for the annual right-of-way fee and any notices under this article.
- E. The owner of each small wireless facility shall provide the Borough with up-to-date contact information. If ownership of a small wireless facility changes, the new owner of the small wireless facility shall provide notice and new contact information to the Borough within 30 days.

§320-6.11 APPLICATION FEES.

An applicant for a permit to install a small wireless facility shall include the following fees with its application:

- A. For an application seeking approval for between one and five co-located small wireless facilities: \$500.
- B. For an application seeking approval of more than five co-located small wireless facilities: \$500 plus \$100 for each co-located small wireless facility beyond five.
- C. For an application seeking approval of a small wireless facility that requires the installation of a new or replacement utility pole: \$1,000.
- D. The fees established by this section shall be adjusted upward by resolution of Borough Council if authorized by Section 7(c) of the Act.

§320-6.12 REMOVAL OF SMALL WIRELESS FACILITIES FROM RIGHT-OF-WAY.

- A. Within 60 days of suspension or revocation of a permit due to noncompliance with this article or the Act, the permit holder shall remove the small wireless facility and any associated equipment, including the utility pole and any support structures if the permit holder's wireless facilities and associated equipment are the only facilities on the utility pole, after receiving adequate notice and an opportunity to cure any noncompliance.
- B. Within 90 days of the end of a permit term or an extension of the permit term, the permit holder shall remove the small wireless facility and any associated equipment, including the utility pole and any support structures if the permit holder's wireless facilities and associated equipment are the only facilities on the utility pole.
- C. A wireless provider which elects to discontinue the use of a small wireless facility shall notify the Borough in writing not less than 45 days prior to the discontinuance of use of the small wireless facility, which notice shall specify when and how the wireless provider will remove the small wireless facility and, if applicable, the pole. The wireless provider shall complete the removal within

45 days of the discontinuance of the use of the small wireless facility. A permit issued under this Article for a small wireless facility which is voluntarily removed shall expire upon the removal of the small wireless facility.

§320-6.13 VIOLATIONS AND PENALTIES.

- A. Violations. It shall be a violation of this article to do or permit the following:
1. To install a small wireless facility prior to obtaining the permit required by this article.
 2. To install a small wireless facility in a manner other than that authorized by the permit.
 3. To place any false or misleading information on an application including, but not limited to, incorrectly identifying the right-of-way width, the identity of the owner of a utility pole, the precise location of the utility pole, or the size and location of any proposed or existing equipment.
 4. To fail to make any payment required by this article or to make a payment by a means which is later dishonored.
 5. To violate any other provision of this article.
- B. Penalties. Any person who violates or permits the violation of any provision of this article shall be liable upon summary conviction therefor to fines and penalties of not less than \$100.00 nor more than \$1,000.00 plus all costs of prosecution, including attorneys' fees, which costs, fines, and penalties may be collected as provided by law. Each day that a violation continues and each section of this article which is violated constitutes a separate violation.

ARTICLE VII
SNOW AND ICE REMOVAL

§320-7.01 REMOVAL FROM SIDEWALKS.

The responsible party for a property fronting upon or along any street within the Borough is hereby required to remove or cause to be removed from all of the sidewalks in front of or alongside such property all snow and ice which has fallen or formed thereon within 24 hours after such snow and ice has ceased to fall or to be formed so that there shall be a clear walk along the entire length thereof at least three feet in width. In the event that snow and/or ice on a sidewalk has become so hard that it cannot be removed without the likelihood of damage to the sidewalk, the responsible party shall, within 24 hours after the snow or ice has ceased to fall or form, cause enough sand or other abrasive to be placed upon the sidewalk to make travel reasonably safe and shall, as soon thereafter as weather permits, cause to be cleared a path in said sidewalk of at least three feet in width. For the purposes of this article, the responsible party shall be considered the person or persons who are the owner of an unoccupied or multiple unit property and the occupant of any single unit property.

§320-7.02 REMOVAL FROM BUILDINGS AND STRUCTURES.

Every responsible party shall remove and clear away, or cause to be removed and cleared away, any accumulation of snow and ice on a building or other structure which is liable to fall on any sidewalk, roadway or other public way. Such work shall be completed within a reasonable time, but not later than 24 hours after the cessation of any fall of snow, sleet or freezing rain.

§320-7.03 REMOVAL FROM FIRE HYDRANTS.

Every responsible party shall remove and clear away, or cause to be removed and cleared away, any accumulation of snow or ice surrounding a fire hydrant located along the frontage of the property of the responsible party. Such work shall be completed within a reasonable time, but not later than 24 hours after the cessation of any fall of snow, sleet or freezing rain.

§320-7.04 DEPOSIT OF SNOW OR ICE RESTRICTED.

No person shall deposit or cause to be deposited any snow or ice on or immediately next to a fire hydrant or on any sidewalk, travel lanes of a street or loading or unloading area of a public transportation system, except that the Borough may mound snow and ice on public cartways incident to the clearing thereof or on curbs, and persons may mount snow and ice on curbs incident to the clearing of sidewalks in business districts.

§320-7.05 REMOVAL BY BOROUGH; COSTS.

In any case where the responsible party shall fail, neglect or refuse to comply with any of the provisions of this article within the time limit prescribed herein, the Borough may proceed immediately to clear all snow and/or ice from the sidewalk, roof or around the fire hydrant on the property for which such person is a responsible party and to collect the expenses of such removal, with an additional penalty of 10% of such costs, from the responsible party or to file a municipal lien against such property.

§320-7.06 QUICK TICKET PROCEDURES

In addition to other enforcement mechanisms available to the Borough under this chapter, the Borough Official is authorized to issue quick tickets for the violation of this article. The fine set forth in the quick ticket shall be established by resolution of Borough Council and shall be payable within fifteen (15) days from the date of issuance of the quick ticket. If the responsible person does not pay the quick ticket within fifteen (15) days, the Borough may proceed in accordance with §320-7.07.

320-7.07 VIOLATIONS AND PENALTIES.

Any person who commits or permits any other person to commit a violation of any provision of this article shall be liable, upon conviction thereof in a summary proceeding, to pay a fine of not less than \$50 nor more than \$1,000 for each offense, together with the costs of prosecution. Each day or portion thereof in which a violation exists shall be considered a separate violation of this article, and each section of this article which is violated shall be considered a separate violation.

ARTICLE VIII

OBSTRUCTIONS AND ENCROACHMENTS

§320-8.01 CELLAR DOORS OPENING ONTO SIDEWALK.

It shall be unlawful for any person to construct, install or maintain any cellar door opening upon or into any sidewalk in the Borough, unless such door shall be constructed of metal or other heavy and durable material, shall, when closed, be level with the pavement and shall not extend more than 51 inches from the building line toward the curb or outer line of the sidewalk.

§320-8.02 POSTS AND POLES ON SIDEWALK AREA.

It shall be unlawful for any person to erect or maintain any post or pole upon any sidewalk or sidewalk area in the Borough for the purpose of supporting any awning, canopy, marquee or portico.

§320-8.03 DISPLAY OR STORAGE OF MERCHANDISE ON SIDEWALK.

It shall be unlawful for any person to display or store any merchandise upon any sidewalk in the Borough unless such merchandise, including any stand, table or support therefor, shall extend not more than four feet from the building line toward the curb or outer line of the sidewalk and shall be not less than six feet in height.

§320-8.04 SCAFFOLDING, BUILDING MATERIALS AND EQUIPMENT ON SIDEWALK.

It shall be unlawful for any person to erect any scaffolding upon or over any sidewalk in the Borough or to store upon any sidewalk any material or equipment used in construction or repairs to the sidewalk or in the construction of any vault thereunder, unless there shall be left a passageway for pedestrians at least four feet in width alongside such scaffolding or other obstruction.

§320-8.05 REGULATION OF BUILDING MATERIALS AND DUMPSTERS.

- A. When any person shall be about to erect or repair any house, building, wall or other structure within the Borough and desires to occupy a part of the public street or sidewalk for placement of building materials, mortar boxes, dumpsters or similar items thereon, he shall make application to the Borough Manager or other designated Borough Official stating the number and extent of such building materials, dumpsters and/or other items for the accommodation of which he desires to occupy said street or sidewalk, the specific location where such person will place the building materials, dumpsters and/or other items and why it is not possible to place such items upon the property to which they relate. If the placement of the requested materials will interfere with the safe passage of vehicular or pedestrian traffic, the Manager or other designated Borough Official shall deny the permit. If the applicant demonstrates that there will be nothing placed in a travel lane to interfere with vehicular passage and a three feet wide pedestrian passage may be maintained, the Manager or other designated Borough Official shall issue a permit to occupy said part of any public street or sidewalk for the purpose stated in the application, not exceeding in extent of the dimensions of the front of the premises about to be built upon or repaired and, further, not exceeding eight feet in width, 13 feet in height and one foot over curb, with a gutter left along the curb 15 inches in height, with cleanout holes, 12 by 18 every 25 feet in length. In case it is desired to mix mortar and place any mortar boxes upon any of the public streets or highways during the erection and repair of buildings, walls or other structures, it shall be required that a watertight box be used. A permit shall identify the dates of the permitted occupancy of the street or sidewalk, and the permit

shall not be valid for more than 30 days.

- B. All building materials and other items shall be neatly maintained. Reflectorized or lighted barricades shall be used. The cartway shall at all times be left unencumbered between said materials or mortar boxes and the opposite curb for the passage of vehicles.
- C. The placement of any dumpster shall be in accordance with all requirements of the Commonwealth of Pennsylvania Motor Vehicle Code and Chapter 350, Vehicles and Traffic. The dimensions of the dumpster shall not exceed eight feet in width by 20 feet in length. The dumpster shall be lighted or reflectorized, or lighted barricades shall be used. The dumpster shall not inhibit vehicle sight distance visibility. The applicant shall provide the Borough with the name and telephone number of the company furnishing the dumpster. Should it be proven subsequent to the placement of a dumpster in the right-of-way that said dumpster creates a hazard, even though a permit has been issued, the Borough Manager or other designated Borough Official or Chief of Police shall have the right to require the permittee to have the dumpster removed within 24 hours.
- D. No building materials, dumpster or other item shall be placed within 15 feet of any fire hydrant or within 50 feet of a railroad track.
- E. If any damage or injury to the cartway, curb or sidewalk shall be caused or done by the use or occupancy of any street or road hereunder, the party to whom such permit shall have been issued shall be responsible and liable for the same and shall restore the cartway, curb and/or sidewalk to its original condition. If the permittee refuses to properly restore the cartway, curb and/or sidewalk to its original condition, the Borough may do so and collect the cost of the same from the permittee.
- F. The cost of a permit shall be set forth, from time to time, by resolution of Borough Council.

§320-8.06 DEPOSIT OF MATERIALS ON STREETS OR OTHER PROPERTIES.

- A. It is hereby declared a public nuisance for any person, when hauling soil, bedrock, concrete, waste material or other material over any public street, road, alley or public property, to allow such material to blow or spill over and upon such street, road, alley, sidewalk or public property or adjacent private property.
- B. It is hereby declared a public nuisance for any person, being the owner of real property or operator of any vehicle, to permit a vehicle entering from upon a public street, road or alley or upon public property to deposit or track dirt, mud, rock or other material from such property.

§320-8.07 REMOVAL OF MATERIALS.

Any person violating the provisions of this article shall cause any deposited material to be removed from the street, road, alley, sidewalk or public property within six hours from the occurrence. In the event of an immediate danger to the public health or safety, the material shall be removed immediately. In the event that deposited material is not so removed, the Borough shall cause such removal, and the cost thereof shall be charged to the person responsible.

§320-8.08 VEHICLE REPAIR ON PUBLIC STREETS.

It shall be unlawful for any person to repair or otherwise perform maintenance of any vehicle upon any public street within the Borough; provided, however, that the following activities shall be permitted if conducted in a manner which does not constitute an obstruction of traffic or hazard to passersby:

- A. Emergency repairs necessary to prevent the obstruction of traffic.
- B. Emergency repairs necessary to permit the removal of a vehicle from a street, alley, or roadway.
- C. Changing of the vehicle's tires.
- D. Washing, waxing, polishing or other cleaning of the vehicle.

§320-8.09 TRIMMING OF OVERHANGING TREES AND SHRUBS REQUIRED.

It shall be the duty of the owners of all real estate located in the Borough to trim and to keep trimmed all trees and shrubbery located upon such real estate or upon or along the abutting street or sidewalk, so that:

- A. There shall at all times be a clear space of at least 14 feet between the lowest portion of such trees and the surface of the street below.
- B. There shall at all times be a clear space of at least eight feet between the lowest portion of such trees and the paved surface of the sidewalk below.
- C. No portion of any such tree or shrubbery shall extend horizontally onto any street at any point less than 14 feet above the surface thereof or onto any sidewalk at any point less than eight feet above the surface thereof.

§320-8.10 VIOLATIONS AND PENALTIES.

Any person violating the provisions of this article shall be subject to the following nonexclusive fines and penalties, one or more of which may be pursued by the Borough concurrently:

- A. A fine or penalty of not less than \$50 and not more than \$1,000 for each and every offense plus costs, including the Borough's reasonable attorneys' fees, such fine or penalty to be collected as provided by law.
- B. The Borough Manager may suspend or revoke any permit issued by the Borough to a person responsible for the violation of this article if the materials unlawfully deposited are a product of work authorized by such permit, such suspension or revocation to continue:
 - (1) Until the Borough has been compensated for any charges incurred by Borough in cleaning up or removing the unlawfully deposited material.
 - (2) Until the person responsible has paid or deposited in escrow any fines or penalties which a Magisterial District Judge determines to be due by reason of a violation of this article.
 - (3) Until such time as the Borough determines that the person responsible has taken adequate precautions to assure that the unlawful depositing of materials will not reoccur.
- C. Any person whose permit shall have been revoked by the Borough Manager may, within 30 days of such suspension or revocation, appeal such decision to Borough Council.

Section 2. Appendix A, Streets and Sidewalks Approval Certificate, and Appendix B, Technical Specifications and Standard Details, attached hereto as Exhibit A, shall be made part of Chapter 320, Streets and Sidewalks.

Section 3. All other sections, parts and provisions of the Code of Ordinances of Millersville Borough shall remain in full force and effect as previously enacted and amended.

Section 4. In the event any provision, section, sentence, clause or part of this Ordinance shall be held to be invalid, illegal or unconstitutional by a court of competent jurisdiction, such invalidity, illegality or unconstitutionality shall not affect or impair the remaining provisions, sections, sentences, clauses or parts of this Ordinance, it being the intent of Borough Council that the remainder of the Ordinance shall be and shall remain in full force and effect.

Section 5. This Ordinance shall take effect and be in force from and after its enactment as provided by law.

DULY ORDAINED AND ENACTED this 12 day of May, 2026, by Borough Council of the Borough Millersville, Lancaster County, Pennsylvania, in lawful session duly assembled.

BOROUGH OF MILLERSVILLE
Lancaster County, Pennsylvania

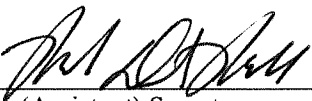
Attest: 
(Assistant) Secretary

By: 
(Vice) President
Borough Council

[BOROUGH SEAL]

Examined and approved as an Ordinance this _____ day of _____, 2026.

By: _____
Mayor

EXHIBIT A

APPENDIX A STREETS AND SIDEWALKS APPROVAL CERTIFICATE

**MILLERSVILLE BOROUGH COUNCIL
STREETS AND SIDEWALKS APPROVAL CERTIFICATE**

At a meeting held on _____, 20__, the Millersville Borough Council approved this project, including the complete set of plans and information which are filed with the Council in File No. _____, based upon its conformity with the standards of the Millersville Borough Streets and Sidewalks Ordinance.

*

*Signatures of the President or Vice President of Council or their designees.

**APPENDIX B - MILLERSVILLE BOROUGH
TECHNICAL SPECIFICATIONS AND STANDARD DETAILS**

Contents

Article I. SPECIAL CONDITIONS OF WORK.....I-1
Article II. TECHNICAL SPECIFICATIONS II-5
Article III. FIGURES..... II-6
Article IV. TYPICAL DETAILSIV-7

TABLES

Table 1 Right-Of-Way, Cartway, Curb and Sidewalk Widths.....IV-7
Table 2 Pavement Designation.....IV-8
Table 3 Driveway Widths.....IV-9

ARTICLE I. SPECIAL CONDITIONS OF WORK

1. GENERAL

The following paragraphs refer to Special Conditions of Work for all contractors who intend to work within the Borough street rights-of-way.

2. STORAGE OF MATERIALS

Materials shall be stored so as to insure the preservation of their quality and fitness for the work. When considered necessary, they shall be placed on wooden platforms, or any other hard, clean surface, not on the ground. They shall be placed under cover and protected from dampness, dust and fire. Stored materials shall be located so as to facilitate prompt inspection. Lawns, grass plots or other private property shall not be used for storage purposes without written permission of the Owner or Leasee.

3. FIRE

The Contractor shall take every precaution to prevent a fire. Open burning is not permitted within the Borough.

4. NIGHT AND SUNDAY WORK

See Millersville Borough Noise Ordinance for requirements.

5. INSURANCE

The Contractor shall secure and maintain insurance policies with the following coverages:

- (a) **Workmen's Compensation:** The Contractor shall take out and maintain during the life of this permit Workmen's Compensation Insurance for all employed at the site of the project. The Contractor shall require any subcontractor to provide the same coverage.
- (b) **Public Liability and Personal Injury: Public Liability Damage:** Public Liability coverage shall be not less than \$500,000 for all damages rising out of bodily injury, including death at any time resulting there from, sustained by any one person in any one accident and a limit of liability of not less than \$1,000,000 aggregate for any such damages sustained by two or more persons in any one accident.

- (c) **Property Damage:** Property Damage coverage shall be not less than \$300,000 for all property damage sustained by any one person in any one accident; and a limit of liability of not less than \$300,000 aggregate for any such damage sustained by two or more persons in any one accident.
- (d) **Explosion, Collapse, and Underground** shall be covered with insurance in limits as required under Public Liability, Personal Injury and Property Damage for each occurrence.
- (e) **Railroad Protective Liability and Property Damage:** When the permit includes work on or under Railroad rights-of-way or properties, the Contractor shall secure and maintain Railroad Protective Liability and Property Damage Insurance. The amount of Insurance, term of policy and name or names of the insured shall be in accordance with current railroad requirements.
- (f) **Independent Contractors Liability Coverage:** Public Liability shall be in an amount not less than \$500,000 for injuries including accidental death to any one person, or in an amount not less than \$1,000,000 on account of each occurrence. Property damage insurance shall not be less than \$300,000.
- (g) **Blasting Coverage** shall be in an amount not less than \$500,000 for injuries including accidental death to any one person, or in an amount not less than \$1,000,000 on account of each occurrence. Property damage insurance shall not be less than \$300,000.
- (h) **Completed Operations Liability** shall be in an amount of not less than \$500,000.
- (i) **Fire and Extended Coverage Insurances:** The Contractor, at his own expense, shall carry insurance upon the insurable value of the work done pursuant to the Permit. Such policies shall provide protection against loss or damage as a result of fire, lightning, or perils covered by an extended coverage endorsement. Policies insuring work done pursuant to the Permit shall be written in the name and for the benefit of the Contractor and the Owner, as their respective interests may appear.
- (j) **Automobile and Truck Public Liability, Bodily Injury, and Property Damage:** Public Liability shall be in an amount of not less than \$500,000, Personal Injury in an amount of not less than \$500,000 and Property Damage in amount of not less than \$500,000.
- (k) **Owner's and Engineer's Liability:** The Contractor shall take out and maintain during the life of this Permit, such Public Liability and Property Damage Insurance as shall protect the Owner and the Engineer from claims for damages for personal injury, including accidental death, as well as from claims for property damages, which may arise from operations connected with or caused by any operation or matter related to this Permit. The amounts of such insurance shall be in accordance with the limits stated in paragraph (b) above.
- (l) **Umbrella Excess Liability Insurance:** The Contractor shall provide a minimum limit of liability of \$1,000,000 per occurrence which shall be in an excess over the primary limits of insurance required in this section.

6. RESPONSIBILITY REGARDING EXISTING UTILITIES AND STRUCTURES

The existence and location of underground utilities, process piping or plant conduits shall be investigated and verified in the field by the contractor before starting work. The Contractor's attention is directed to the existing Local, State and Federal regulations, especially the Pennsylvania One Call System Inc. 1-800-242-1776.

Excavation in the vicinity of existing structures and utilities shall be carefully done. The Contractor should call the Pennsylvania One Call System before he starts to dig.

The Contractor shall be held liable for any damage done by reason of breaking any water, sewer, gas, telephone, electric, process piping, plant conduits, or other utility service. The Contractor shall notify all utility companies and the Owner's operating personnel in advance of construction and cooperate with agents of these companies and the Owner during the progress of the work. If any lines or services become broken or damaged during the progress of the work, the Contractor shall cause them to be repaired at once at his own expense. Delays which would result in adjoining residences or businesses having to go overnight or for needlessly long periods during the day without utilities, or the plant operation to be adversely affected, will not be tolerated. The Owner reserves the right to remedy such delays or neglect by ordering outside parties to make repairs at the expense of the Contractor without written notice.

Care shall be taken not to move, any sewers, culverts, water, gas, electric, telephone, or other pipes or poles or structures. In crossing, or in running parallel with or near utility lines, process piping or plant conduits, such sewers, culverts, water, gas, electric, telephone, or other pipes or poles or structures shall be securely hung, braced or supported in place until the work is completed. Whenever it is necessary to interfere with said structures, the Contractor, at his own expense, shall maintain their respective services, and if necessary, lay temporary lines or structures.

The Contractor shall repair all damage done to any structures and shall keep them in repair for a period of one year after the completion of the work.

7. EROSION AND SEDIMENTATION CONTROL

The Contractor shall adhere to the regulations relating to the control of erosion and sedimentation implemented by Pennsylvania under Chapter 102 of Public Law 1987, as amended.

8. PREVENTION OF ENVIRONMENTAL POLLUTION AND PRESERVATION OF PUBLIC NATURAL RESOURCES

The Contractor shall adhere to the provisions of the Pennsylvania Act No. 247 of 1972 relating to the prevention of environmental pollution and the preservation of public natural resources.

9. MAINTENANCE CREW

The Contractor shall make available 24 hours a day a maintenance crew for the repairs and maintenance of trenches or other work which has become hazardous to the public or plant operations as a result of trench settlement or other reasons.

The Contractor shall make the name, address and telephone number of a responsible maintenance person available to the Borough. If the maintenance person so assigned fails to respond, or the Contractor fails to make the repairs within a reasonable period of time after being directed by the Borough, then the necessary repairs or maintenance shall be performed by others and the full costs of the work charged to the Contractor.

10. WORK ZONE TRAFFIC CONTROL

The Contractor shall provide flagmen, signs, barricades, etc. as required to help ensure safe and efficient traffic movement through the work zones, and also to provide safety for the work force. All work zone traffic control shall be in accordance with PennDOT Publication 213, entitled, "Work Zone Traffic Control", latest edition.

ARTICLE II. TECHNICAL SPECIFICATIONS

The Pennsylvania Department of Transportation Specifications Publication 408, with latest revisions and attachments shall be considered part of these specifications, and all work shall conform to those specifications. Any items that are not specifically listed here in these specifications shall be governed by the appropriate section in Publication 408. Where conflicts occur between Publication 408 and the specifications in this Ordinance, the more restrictive specifications shall apply.

All finished gutter joints at the curb line and all surface joints of the streets and drives shall receive a bituminous seal coat of Emulsified Asphalt at least six (6) inches in width.

At the completion of a project, the Contractor shall deliver a written statement to the Borough certifying that his work was performed in accordance with these specifications.

ARTICLE III. FIGURES

Figure F-1 Driveway Grade

Note: In areas with sidewalk and curb, the driveway aprons shall be designed to meet the requirements of the Americans with Disabilities Act and PennDOT specifications for driveway aprons (Pub 72 Standards for Roadway Construction Standard RC-67M).

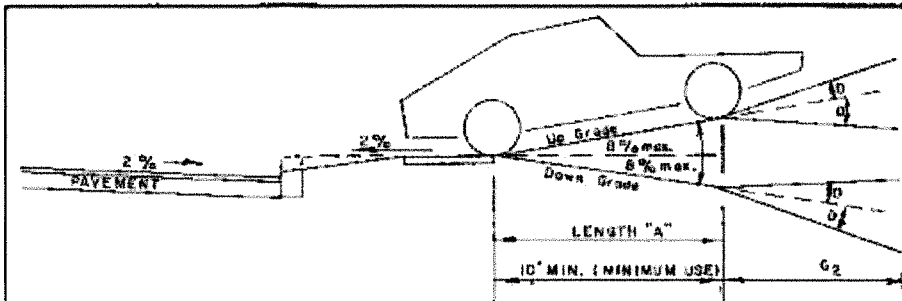

FOR GRADE CHANGES GREATER THAN THOSE SHOWN ABOVE, VERTICAL CURVES AT LEAST 10 FEET LONG SHALL BE CONSTRUCTED AND LENGTH "A" SHALL BE INCREASED.

GRADES (G₂) SHALL BE LIMITED TO 15% FOR MINIMUM USE DRIVEWAYS

MAXIMUM GRADE CHANGE (D)	DESIRABLE	MAXIMUM
MINIMUM USE	+ 6 %	CONTROLLED BY VEHICLE CLEARANCE

MAXIMUM DRIVEWAY GRADE **FIGURE # 1**

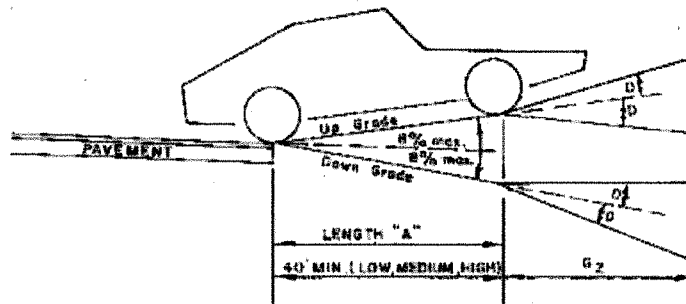

FOR GRADE CHANGES GREATER THAN THOSE SHOWN ABOVE, VERTICAL CURVES AT LEAST 10 FEET LONG SHALL BE CONSTRUCTED AND LENGTH "A" SHALL BE INCREASED.

MAXIMUM GRADE CHANGE (D)	DESIRABLE	MAXIMUM
HIGH VOLUME DRIVEWAY	+ 1%	+ 3%
MEDIUM VOLUME DRIVEWAY	+ 3%	+ 5%
LOW VOLUME DRIVEWAY	+ 0%	CONTROLLED BY VEHICLE CLEARANCE

GRADES (G₂) SHALL BE LIMITED FROM 5% TO 6% FOR LOW, MEDIUM OR HIGH VOLUME DRIVEWAYS.

ARTICLE IV. TYPICAL DETAILS

Table 1 Right-Of-Way, Cartway, Curb and Sidewalk Widths

	(A) ROW (FEET)	(B) Cartway (FEET)	(C) Curb Type	(D) Sidewalk Width (FEET)
Road Designation				
Collector Or Arterial Street (3-lane)	60'	38'	Vertical	5'
Collector Or Arterial Street (2-lane)	60'	30'	Vertical	5'
Local Street (Parking Both Sides)	50'	34'	Vertical	5'
Local Street (Parking 1 Side)	50'	30'	Vertical	5'
Local Street (No Parking)	50'	26'	Vertical	5'
Alley	14'	14'	NA	NA
Alley (Traditional Neighborhood Development, one- way)	10'	10'	NA	NA

Note: Vertical curb reveal shall be 6" or 8".

Table 2 Pavement Designation

LOCAL ROADS

ID	DEPTH (inches)	COURSE DESCRIPTION	AGG.	PG	ESALS
I	1 ½"	S.A.M.D., WMA Wearing Course, SRL H	9.5mm	PG 64-22	
II	2"	S.A.M.D., WMA Binder Course	19.5mm	PG 64-22	
III	4"	S.A.M.D., WMA Base Course	25.0mm	PG 64-22	
IV	6"	PennDOT 2A Coarse Aggregate			
		S.A.M.D. Superpave Asphalt Mixture Design			

COLLECTOR & ARTERIAL ROADS

ID	DEPTH (inches)	COURSE DESCRIPTION	AGG.	PG	ESALS
I	2"	S.A.M.D., WMA Wearing Course, SRL H	9.5mm	PG 64-22	
II	3"	S.A.M.D., WMA Binder Course	19.5mm	PG 64-22	
III	5"	S.A.M.D., WMA Base Course	25.0mm	PG 64-22	
IV	6"	PennDOT 2A Coarse Aggregate			
		S.A.M.D. Superpave Asphalt Mixture Design			

NOTES:

Min/Max Lift is 2"/3" for Binder and 3"/5" for Base Course.

Binder Course shall be installed within 30 days of placement of the Base Course materials, or before traffic from any vehicles greater than a standard automobile, whichever is sooner.

Table 3 Driveway Widths

	Minimum Width (feet)	Maximum Width (Feet)	Minimum Radius (feet)	Maximum Radius (feet)		
Driveway Classifications						
Minimum Use	9'	14'	NA	10'		
Low-Volume (One Way)	10'	20'	15'	35'		
Low -Volume (Two Way)	20'	24'	15'	35'		
Medium-Volume (One Way)	10'	14'	15'	50'		
Medium-Volume (Two Way)	20'	28'	15'	50'		
High Volume (One Way)	10'	14'	15'	50'		
High Volume (Two Way)	20'	28'	15'	50'		

NOTES

1. SEE TABLE 1 FOR RIGHT-OF-WAY, CARTWAY, CURB AND SIDEWALK (A,B,C,D)
2. ALL LONGITUDINAL JOINTS WILL BE SEALED WITH PG 64-22
3. AN ASPHALT TACK COAT SHALL BE APPLIED BETWEEN EACH LAYER OF PAVEMENT.

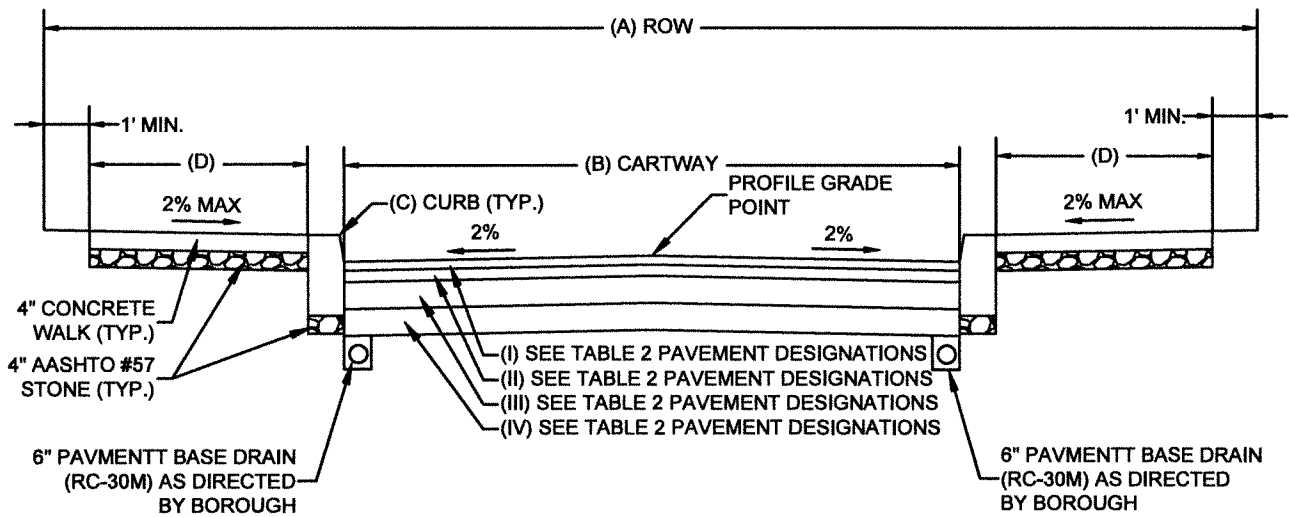

TYPICAL STREET CROSS SECTION
(NOT TO SCALE)

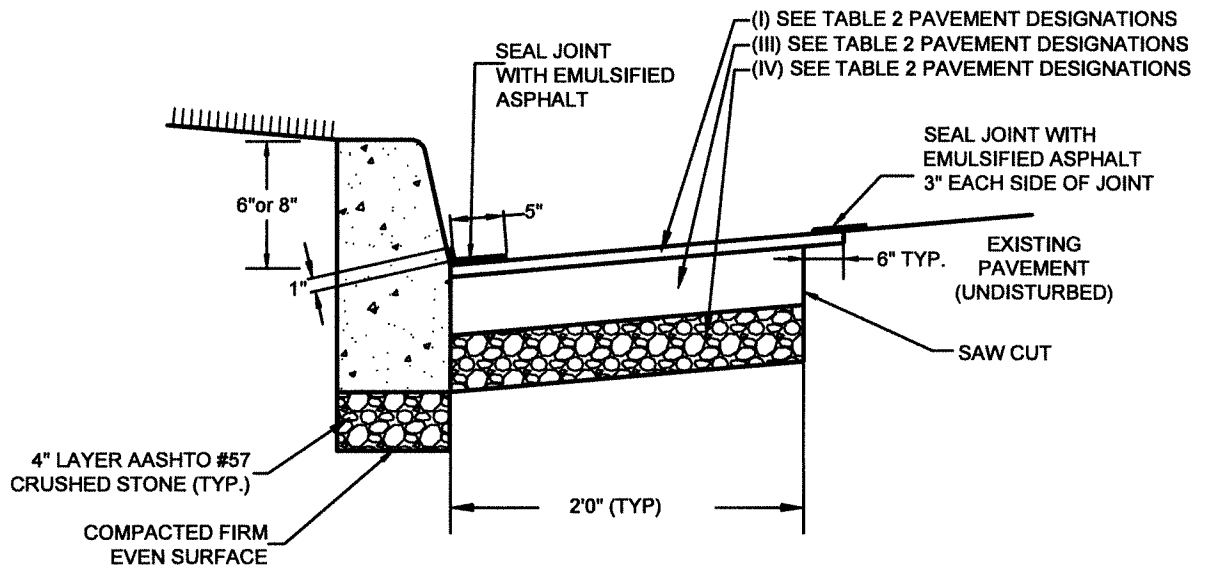

PAVEMENT RESTORATION

(NOT TO SCALE)

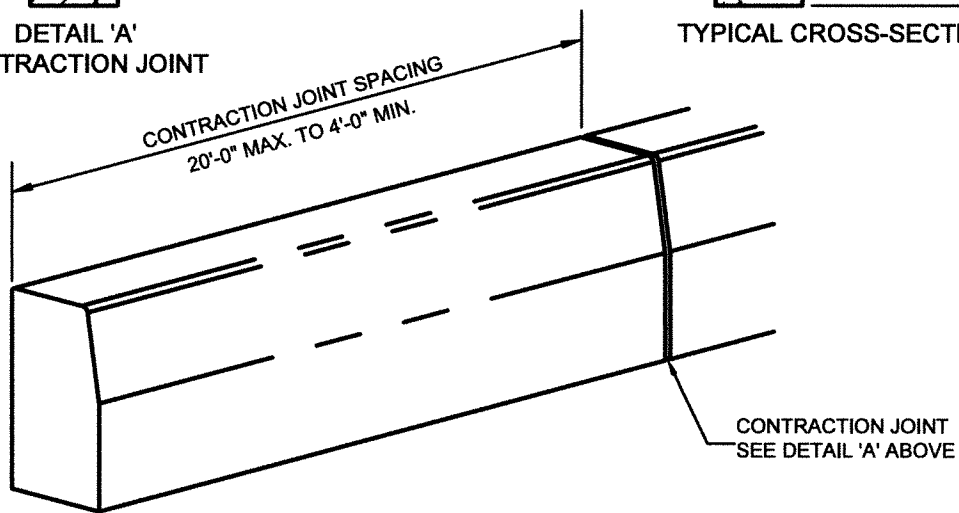
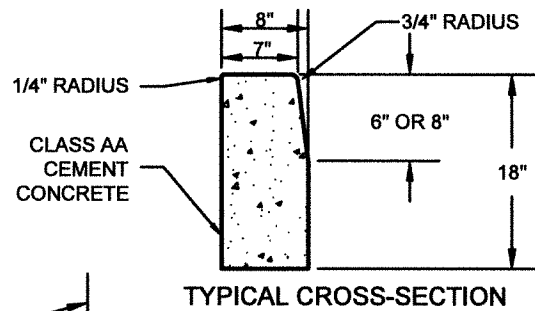
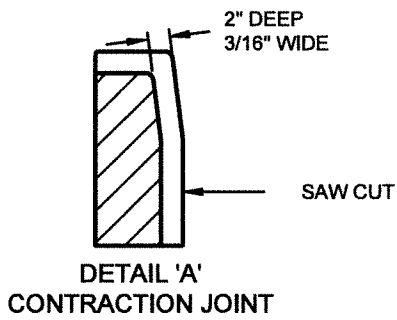

STANDARD VERTICAL CURB

(NOT TO SCALE)

* MEET CURRENT
ADA STANDARDS
AT DRIVEWAYS

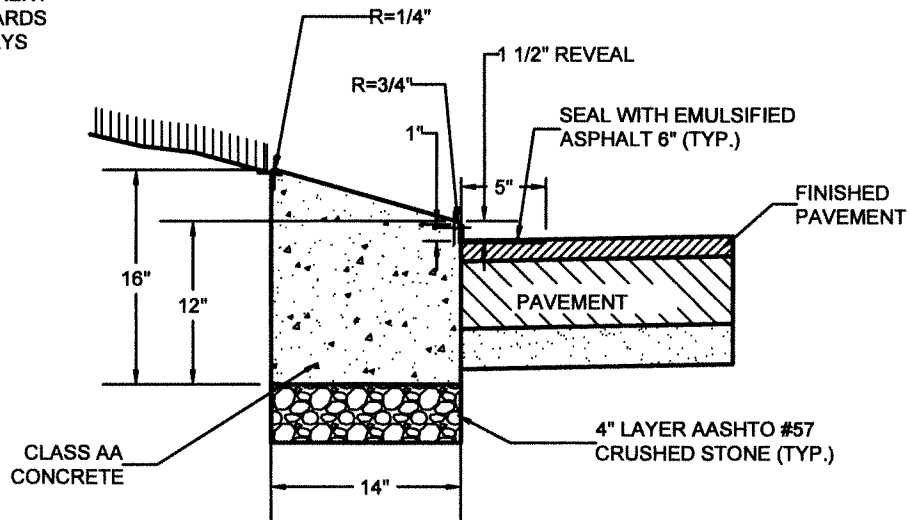

STANDARD SLANT CURB

WHERE APPROVED BY BOROUGH
(NOT TO SCALE)

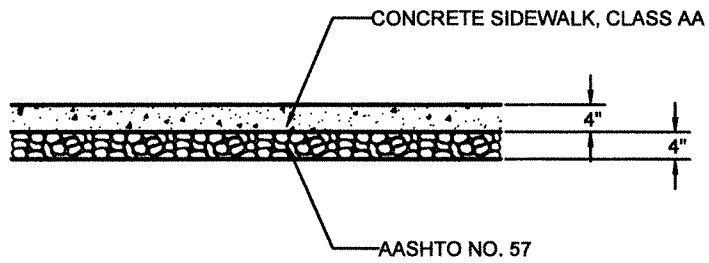

CONCRETE SIDEWALK 4" THICK DETAIL

(NOT TO SCALE)

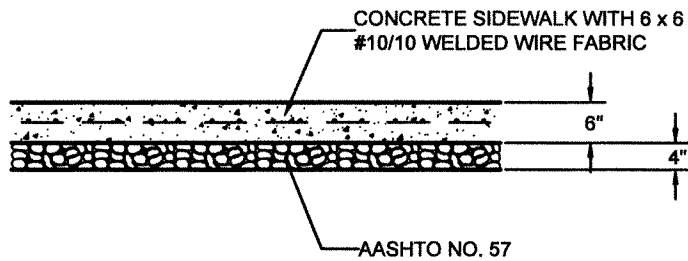

CONCRETE SIDEWALK 6" THICK DETAIL

(NOT TO SCALE)

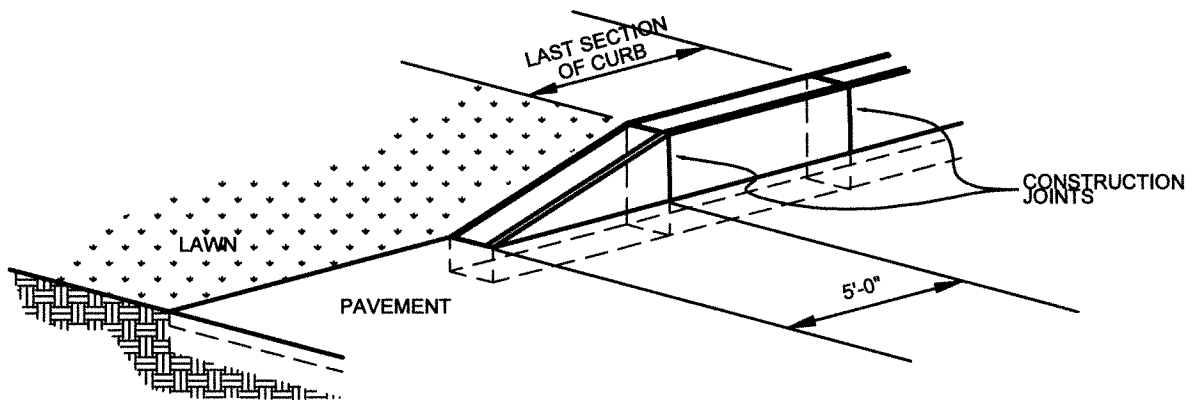

VERTICAL CURB END TREATMENT
 (NOT TO SCALE)

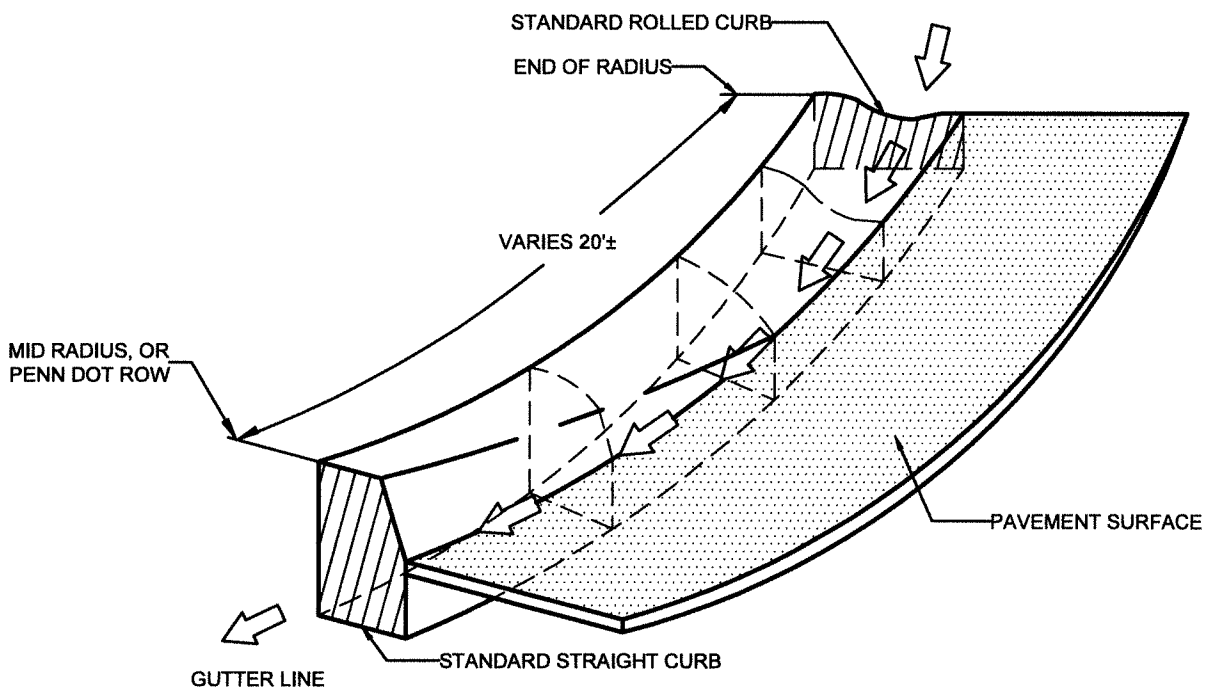

CURB TRANSITION DETAIL

(NOT TO SCALE)

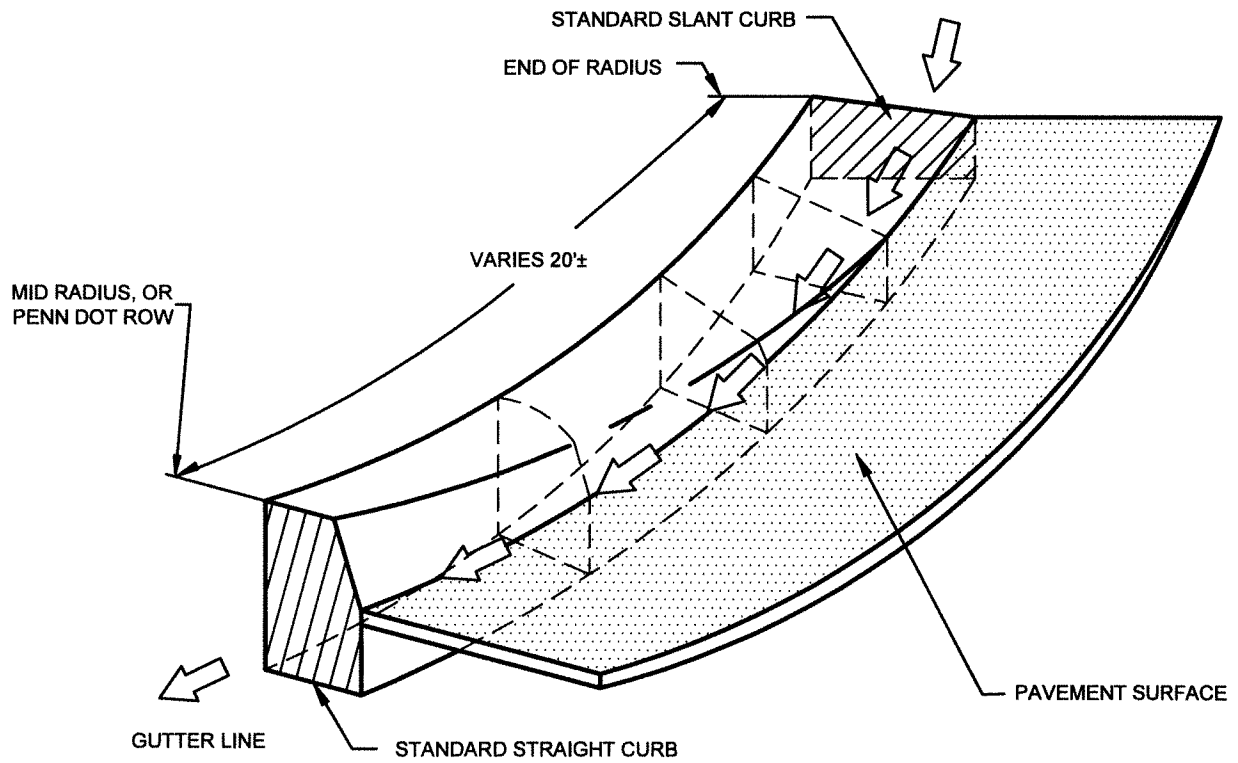

CURB TRANSITION DETAIL

(NOT TO SCALE)

NOTE:

1. SEE PENN DOT PUB 72 RC-30 M FOR COMPACTION REQUIREMENTS.
2. DETAILS SPECIFYING PAVING AND BACKFILLING PROCEDURES AND MATERIALS SHALL BE OBTAINED FROM THE BOROUGH PRIOR TO ANY STREET OPENING WORK. THE TYPE OF BACKFILL MATERIAL SHALL BE AS DIRECTED BY THE PUBLIC WORKS DIRECTOR.

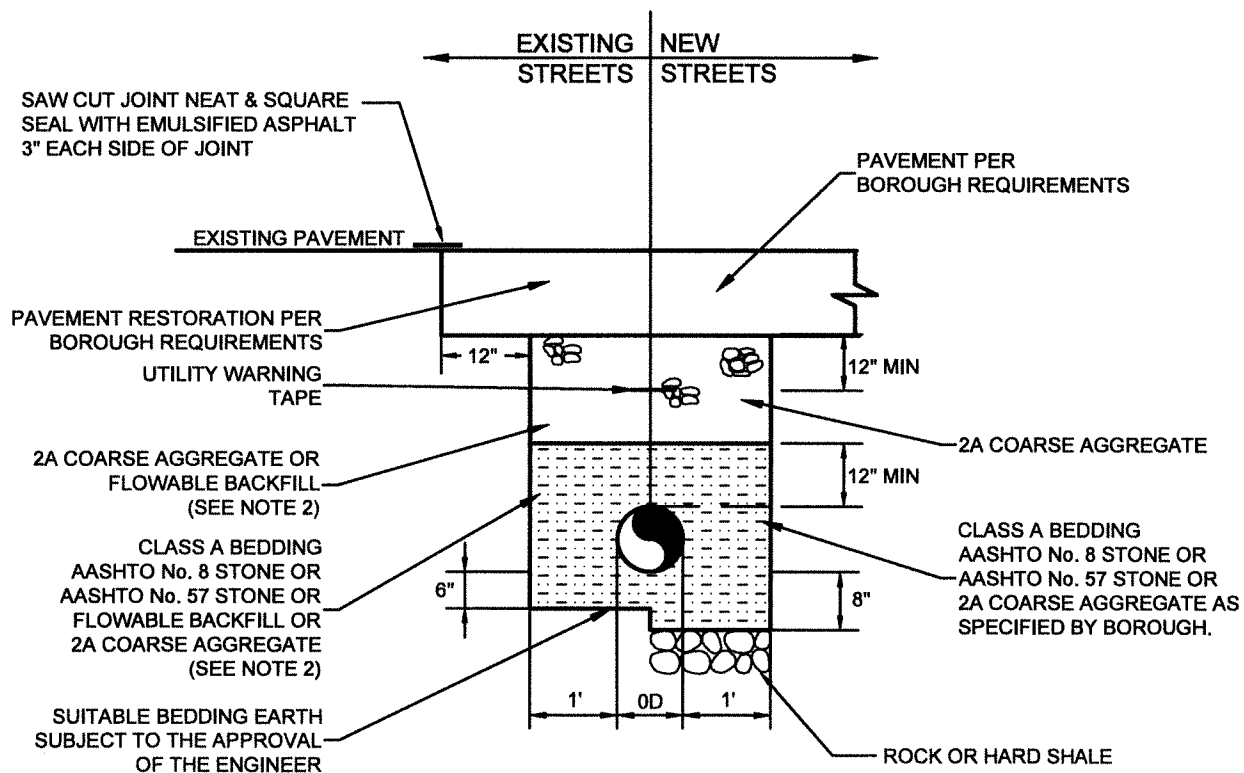

STORM SEWER TRENCH DETAIL BOROUGH ROW

NOT TO SCALE

NOTE:

1. SEE PENN DOT PUB 72 RC-30 M FOR COMPACTION REQUIREMENTS.
2. DETAILS SPECIFYING PAVING AND BACKFILLING PROCEDURES AND MATERIALS SHALL BE OBTAINED FROM THE BOROUGH PRIOR TO ANY STREET OPENING WORK. THE TYPE OF BACKFILL MATERIAL SHALL BE AS DIRECTED BY THE PUBLIC WORKS DIRECTOR.

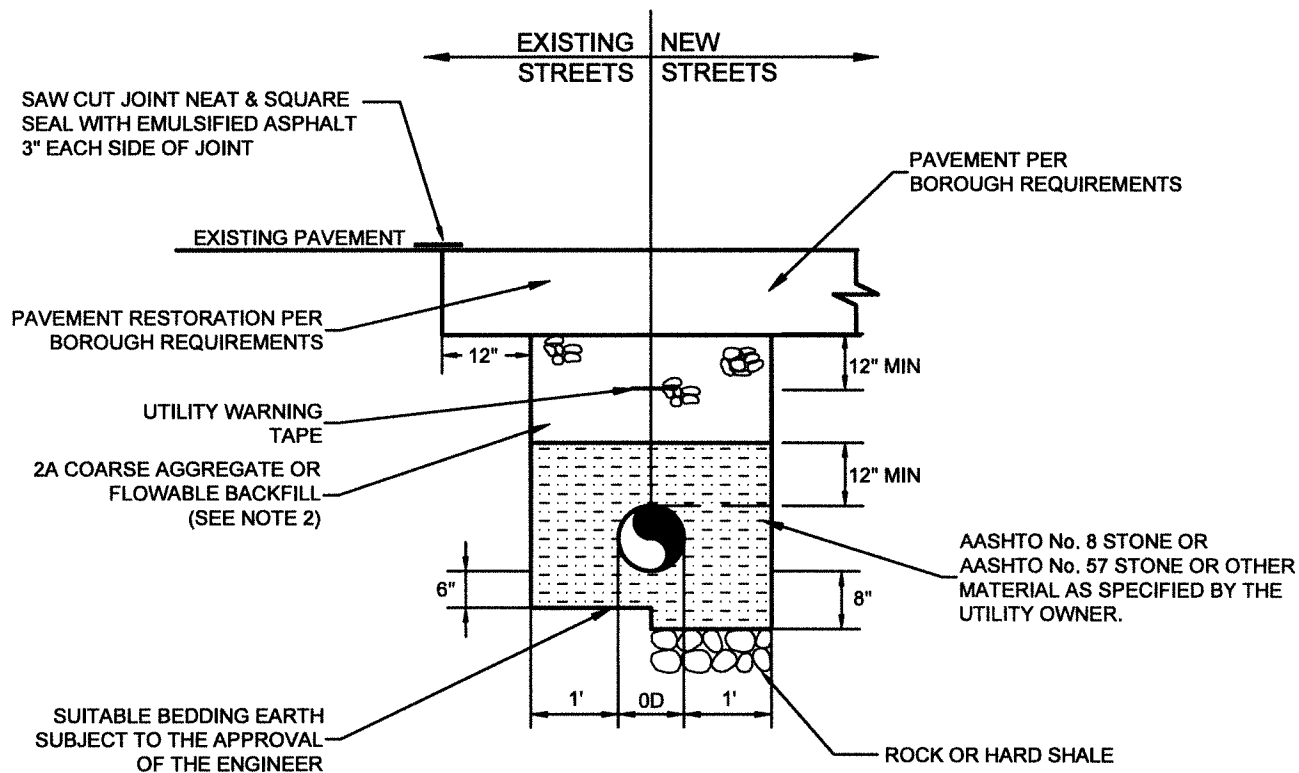

UTILITY TRENCH DETAIL BOROUGH ROW

NOT TO SCALE